

# *THE PINETREE INTERTIE SYSTEM*

## OPERATIONS MANUAL

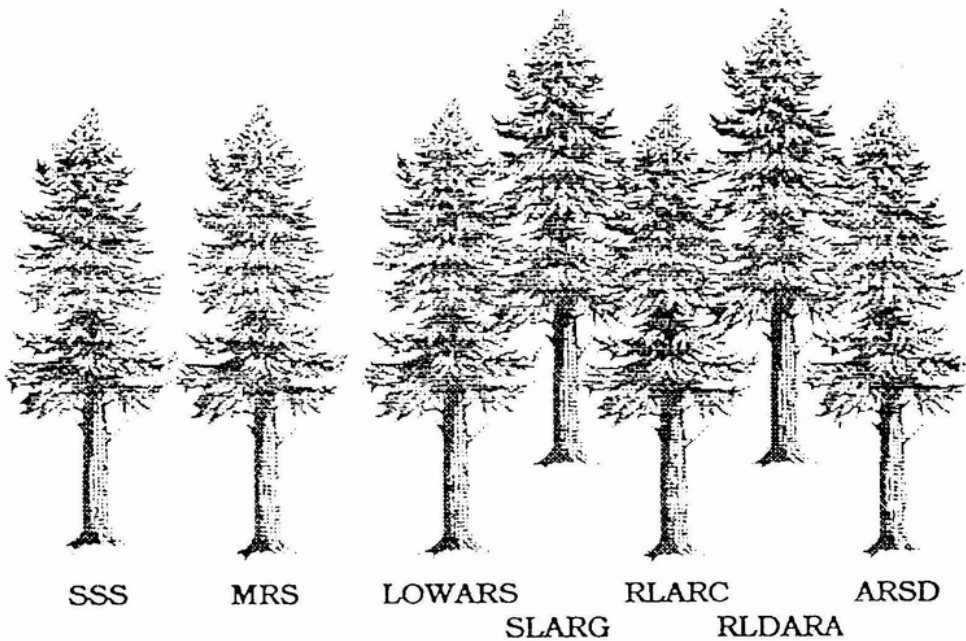

**THE LAKE OF THE WOODS AMATEUR RADIO SOCIETY, INC  
THE MANITOBA REPEATER SOCIETY, INC  
THE RAINY LAKE AMATEUR RADIO CLUB  
TRIPLE S COMMUNICATIONS GROUP, INC  
AMATEUR RADIO SOCIETY OF DRYDEN  
SIOUX LOOKOUT AMATEUR RADIO GROUP  
RED LAKE DISTRICT AMATEUR RADIO ASSOCIATION**

## TABLE OF CONTENTS

<a href="#"><u>System Coordinators.....</u></a>	<a href="#"><u>2</u></a>
<a href="#"><u>User Codes - Crib Sheet.....</u></a>	<a href="#"><u>3</u></a>
<a href="#"><u>How it all began.....</u></a>	<a href="#"><u>4</u></a>
<a href="#"><u>How the system works.....</u></a>	<a href="#"><u>5</u></a>
<a href="#"><u>How to operate the system.....</u></a>	<a href="#"><u>6</u></a>
<a href="#"><u>Example of accessing a remote repeater.....</u></a>	<a href="#"><u>8</u></a>
<a href="#"><u>An explanation of "user" codes.....</u></a>	<a href="#"><u>8</u></a>
<a href="#"><u>Configuration codes.....</u></a>	<a href="#"><u>10</u></a>
<a href="#"><u>Telemetry codes.....</u></a>	<a href="#"><u>13</u></a>
<a href="#"><u>Buffers (Voice messages).....</u></a>	<a href="#"><u>14</u></a>
<a href="#"><u>Some general rules for operating a repeater.....</u></a>	<a href="#"><u>15</u></a>
<a href="#"><u>Your participation in emergencies.....</u></a>	<a href="#"><u>17</u></a>
<a href="#"><u>Your participation in highway accidents or other incidents....</u></a>	<a href="#"><u>17</u></a>
<a href="#"><u>Simplex Frequencies.....</u></a>	<a href="#"><u>18</u></a>
<a href="#"><u>Repeater Data base.....</u></a>	<a href="#"><u>19</u></a>

## APPENDICES

*System Schematic*

&

*Repeater Data Sheets:*

[VE3DRY – DRYDEN](#)

[VE4CDN – MORRIS](#)

[VE4GIM – GIMLI](#)

[VE3LWR – KENORA](#)

[VE4FAL – FALCON LAKE](#)

[VE4ARM – AUSTIN](#)

[VE3RBK – BLACKHAWK](#)

[VE4MAN – STARBUCK](#)

[VE4PTG – PORTAGE](#)

[VE3RLC - FORT FRANCES](#)

[VE4MBR – SELKIRK](#)

[VE3RSN – SIOUX NARROWS](#)

[VE4MIL – MILNER RIDGE](#)

[VE3YXL – SIOUX LOOKOUT](#)

[VE4HS – BRUXELLES](#)

[VA3IGN – IGNACE](#)

[VE4VJ - WINNIPEG \(UHF\)](#)

[VA3BPL – BEARPAW](#)

[VE4WPG – WINNIPEG](#)

[VE3VBY- CAMP ROBINSON](#)

[VE4EMB – HADASHVILLE](#)

## **SYSTEM COORDINATORS**

### **THE LAKE OF THE WOODS AMATEUR RADIO SOCIETY, INC.**

VE3JJA - WOODY LLNTON      BOX 387 LINDSY ROAD POX 1N0, SIOUX NARROWS, ON,  
Telephone – (807)-226-2665      [ve3jja@rac.ca](mailto:ve3jja@rac.ca)

### **THE MANITOBA REPEATER SOCIETY, INC.**

TECHNICAL CHAIRPERSON      598St. Mary's Road, Winnipeg, MB R2M 3L5  
Telephone – (807)-944-914

### **THE RAINY LAKE AMATUER RADIO CLUB**

VE3BVC – BILL WISHART      310 CROWE ST, FORT FRANCES, ON, P9A 2K8  
Telephone – (807)-274-5122

### **TRIPLE S COM MUNICATIONS GROUP, INC.**

VE4UB - BILL BOWMAN      744 CHRISTIE AVE, SELKIRK, MB, R1A 2H9  
Telephone – (204)-482-3402      [bill@bmsl.ca](mailto:bill@bmsl.ca)

### **AMATEUR RADIO SOCIETY OF DRYDEN**

VE3MOR -GARY MCNALLY      SITE 110 BOX 32 RR 1, DRYDEN, ON, P8N 2Y4  
Telephone – (807)-938-1034      [gvmcnally@drytel.net](mailto:gvmcnally@drytel.net)

VA3EXT –SCOTT MOODY      RR#3 SITE 304 BOX 5, DRYDEN, ON, P8N 3G2  
Telephone (807)937-2062      [va3ext@rac.ca](mailto:va3ext@rac.ca)

### **SIOUX LOOKOUT AMATEUR RADIO GROUP**

VA3ADI – ADI LINDEN      BOX 582 110 KING ST. SIOUX LOOKOUT, ON P8T 1A8  
Telephone – (807)-737-7296      [adi@adis.on.ca](mailto:adi@adis.on.ca)

### **RED LAKE DISTRICT AMATEUR RADIO GROUP**

VE3OPG – ORVILLE GENTES      BOX 887, 9 CROSSCUT STREET, RED LAKE, ON, P0V 2M0  
Telephone – (807)-735-

### **THE PINETREE INTERTIE SYSTEM OPERATIONS MANUAL**

*Original Version, April 1994*

**VE3WDX/VE4BJ - BILL STUNDEN SK**

*Revised Version started, August 2002 Dedicated to VE3WDX/VE4BJ - BILL STUNDEN SK*

*Please contact me in regards to updates of this manual.*

VA3EXT - SCOTT MOODY      RR#3 SITE 304 BOX 5, DRYDEN, ON, P8N 3G2

Telephone (807)937-2062      [va3ext@rac.ca](mailto:va3ext@rac.ca)

Thanks to Derek Hay VE4HAY, Grant Delaney VA4GD, and Gord Snarr VE4GLS, for info and editing.

## USER CODES - CRIB SHEET

### #30 - VE3LWR-KENORA

LINK 1 to S'NARROWS - VE3RSN  
LINK 2 to FALCON LAKE - VE4FAL

### #32 - VE3RSN-SIOUX NARROWS

LINK 1 to KENORA - VE3LWR  
LINK 2  
LINK 3 to DRYDEN - VE3DRY

### #38 - VE3DRY-DRYDEN

LINK 1 to S'NARROWS - VE3RSN  
LINK 2 to S'LOOKOUT - VE3YXL  
LINK 3  
LINK 4 to BEARPAW - VA3BPL  
LINK 5 to CAMP ROB VE3VBY  
Link 4 & Link 5 Remote Base to **VE3DRY**

### #40 - VE4FAL-FALCON LAKE

LINK 1 to KENORA - VE3LWR  
LINK 2 to MILNER RIDGE - VE4MIL  
*Note: VHF Hotlink to VE4EMB*

### #42 - VE4MIL- MILNER RIDGE

LINK 1 to STARBUCK - VE4MAN  
LINK 2 to FALCON L - VE4FAL  
LINK 3 to SELKIRK - VE4MBR

### #44 - VE4GIM-GIMLI

LINK 1 to WINNIPEG - VE4WPG

### #45 - VE4WPG-WINNIPEG

LINK 1 to VE4VJ (UHF)  
LINK 2 to STARBUCK - VE4MAN  
LINK 3 to MILNER - VE4MIL  
LINK 4 to GIMLI - VE4GIM

### #46 - VE4MAN-STARBUCK

LINK 1 to WINNIPEG - VE4WPG  
LINK 2 to PORTAGE - VE4PTG  
LINK 3 to MORRIS - VE4CDN

### #47 - VE4CDN-MORRIS

LINK 1 to STARBUCK - VE4MAN

### #48 - VE4HS-BRUXELLES

LINK 1 to PORTAGE - VE4PLP

### Legend

**Pink -** Possible Future Links

## CONTROL CODES

**505** – Disconnects Repeater from the linking system

**506** – Re-connects Repeater to the linking system

**701** – Connects Link 1- MACRO 401

**702** – Connects Link 2- MACRO 402

**703** – Connects Link 3- MACRO 403

**704** – Connects Link 4- MACRO 404

**710** – Disconnects Link 1- MACRO 410

**720** – Disconnects Link 2- MACRO 420

**730** – Disconnects Link 3- MACRO 430

**740** – Disconnects Link 4- MACRO 440

1 – Prefix the codes to your local repeater with a “star” (\*), eg \*505. “Star” not required when accessing distant controller.

# THE PINETREE INTERTIE SYSTEM

## How it all began ....

About 1985, the Manitoba Repeater Society, MRS, (formerly the Winnipeg Repeater Society), decided to link their repeaters together using a UHF backbone and controllers manufactured by a club member in Winnipeg. The repeaters that were linked consisted of Neepawa, Starbuck, Winnipeg, Hadashville and Gimli. Several years later the Lake of the Woods Amateur Radio Society; LOWARS, installed a similar system using the same controllers to link Sioux Narrows, Kenora and Falcon Lake. Both systems suffered shortcomings in that the link between Hadashville and Winnipeg was not reliable and it was necessary to link Kenora to Falcon Lake via an interface at the Kenora Airport. In addition the audio through the systems was not the best and an annoying "squelch tail" was prevalent. However, the development and the use of the two systems did provide a technical and user learning experience notwithstanding the extended area coverage.

Through the course of events and mainly because the person who built the controllers moved to the west coast it became increasingly difficult to maintain the systems. During the summer of 1991, LOWARS decided to replace the controllers with modern units and a market study was implemented. The urgency in this regard was compounded when the Kenora repeater was hit by lightning and the controller became a basket case. The study was completed on November 17th 1991 and the Palomar Telecom 700 series of controller was recommended for the following reasons:

- (1) The controllers are wired and tested and do not require interface requirements, adapters, tie-ons or special apparatus.
- (2) Adequate warranty and follow-up capability.
- (3) Remote or site programmable.
- (4) Expansion capability.
- (5) Auto-Patch.
- (6) Voice ID, paging, etc. not required.
- (7) Commercial quality and reliability.

On this basis, LOWARS ordered and received delivery of three of the controllers in the summer of 1992. A unit was installed at Sioux Narrows and another at Kenora along with replacement UHF transceivers. The Falcon Lake unit was not installed until October 1993, being delayed until authority was received to install the UHF equipment at the site which eliminated the interface at the Kenora airport. This leg was completed in December 1993.

In the meantime MRS made the decision to rebuild their systems and install the Palomar controllers. On August 13th, 1994 they installed new equipment at Neepawa and Starbuck along with Palomar controllers, thus linking the two sites. They also installed a new repeater at Milner Ridge with a Palomar controller in the spring of 1994. Subsequently, this equipment was moved to a new site and re-established as a repeater only. New repeater equipment was installed at St Jean (VE4CDN) on September 25th, 1994 and linked into Starbuck (VE4MAN). On November 19th, 1994, the linking equipment was installed at Milner Ridge (VE4MIL), which completed the linking between MRS and LOWARS from Starbuck (VE4MAN) to Falcon Lake (VE4FAL) with the complete system being from Neepawa (VE4NEP) through to Fort Frances (VE4RLC). This included an offshoot to St Jean (VE4CDN).

During the summer of 1993, the Rainy Lake Amateur Radio Club, RLARC, of Fort Frances obtained two Palomar 700 series controllers. One unit was installed along with a new repeater, VE3RBK at Blackhawk. The second controller was installed at VE3RLC in Fort Frances, along with new VHF repeater equipment and linked to Blackhawk on May 8, 1994.

A Palomar controller was installed at the Selkirk, (VE4MBR) repeater on September 18th, 1994. This repeater will join the INTERTIE System in the near future.

The Amateur Radio Society of Dryden purchased a Palomar controller and they joined the Intertie System on December 24th, 1994.

The Sioux Lookout Amateur Radio Group will join the INTERTIE by the time this manual is printed.

## How the system works ....

The INTERTIE System, while a complete system in itself, actually consists of a number of systems that may be joined together as necessary. There are two sub-systems, namely the VHF/UHF repeaters along with a second sub-system that links the repeaters together on demand. All of this is controlled by the Palomar controllers, which are shown on the attached system schematic. *Figure 4*, and identified by a double rectangular box.

Each of the repeaters operate in the normal repeater mode and isolated from the linking equipment until a demand is placed upon the associated Palomar controller. If you do not hear a courtesy beep, then your repeater is isolated from the linking equipment. However, if you hear a *beep bop*, then your repeater is connected to the linking system. A beep bop is two tones generated on the repeater output one second after the repeater user releases their press-to-talk switch. It is a high pitch tone followed by a low pitch tone and signifies that your repeater is connected to the INTERTIE system. Please wait for the courtesy beep bop before commencing your transmission so that someone with an emergency or other urgent reason can announce themselves through the INTERTIE system.

We are using the Palomar Telecom, Inc. RBC700 series of controllers in a variety of configurations. They are manufactured so that they will handle up to six different radio sources with optional phone patch simultaneously. This is done with on-card squelch detectors, which processes the audio from the receiver discriminator and then produces audio to drive the transmitters modulator circuitry directly. It processes the audio with as little distortion as possible and is nearly flat from 100 hertz to 7 kilohertz i.e. "what goes in comes out" with as little change as possible.

## How to operate the system ....

A number of Amateurs have been identified as "Control Operators". They are available to you in the event you have any questions or can be of assistance to you. You can make your enquiry to any one of them, not necessarily the ones identified with your repeater. The control operators are

<b>DRYDEN:</b>	<b>VE3MOR – Gary</b>	<b>VA3EXT – Scott</b>
<b>FALCON LAKE:</b>	<b>VE3EFY – Dale</b>	<b>VE4HAY – Derek</b>
<b>FORT FRANCES:</b>	<b>VE3BVC – Bill</b>	<b>VE3WGW – Jerry</b>
<b>IGNACE:</b>	<b>VA3WGD -Wally</b>	<b>VA3RGA - Rick</b>
<b>KENORA:</b>	<b>VE3EFY – Dale</b>	<b>VE3NNB – Karl</b>
<b>MINNEDOSA:</b>	<b>VE4UZ - Terry</b>	
<b>SELKIRK:</b>	<b>VE4UB – Bill</b>	<b>VE4RA – Rick</b>
<b>SIOUX LOOKOUT:</b>	<b>VA3ADI – Adi</b>	
<b>SIOUX NARROWS:</b>	<b>VE3JJA – Woody</b>	<b>VE3NNB – Karl</b>
<b>WINNIPEG:</b>	<b>VE4GLS – Gord</b>	<b>VE4HAY - Derek</b>

1. The analogy for the INTERTIE system is to consider it the same as your local telephone system. Refer to - **FIGURES 1,2 and 4.**
2. The telephone system contains a number of areas, which includes yours as an isolated area under normal conditions. To make a telephone call it is only necessary to dial or key in a seven-digit number and you are connected to your ongoing correspondent in your city or town. The same thing happens with your repeater in that you call your party by using your Amateur Radio call signs instead of dialing the seven digit numbers
3. With a telephone system to connect to another area, you enter the digit 1 (or 0) but in our case we key in a star and a three-digit code, which will connect your repeater to the Palomar controller. Once that connection has been made, then it is necessary to connect the Palomar controller to the appropriate UHF link transceiver. Your repeater and the Palomar controller are now connected to the linking system.
4. Now that you are connected to the long distance network (INTERTIE) system, we need to connect to the Palomar controller associated with the distant repeater that you desire. Each of the Palomar controllers has a distinctive "**Link Prefix**" three-digit code or in telephone terms an "**area code**". When you key in the "**Link Prefix**" code your circuit is completed from your repeater to the distant Palomar controller. It is necessary to connect the distant Palomar controller to the repeater of your selection by sending a three-digit code (star is not required). You are now connected to the repeater that you desire.

5. In summary, your DTMF tones and /or voice transmissions follow the following path:
  - (a) Your repeater to the associated controller.
  - (b) Your associated controller to the specified UHF linking transceiver.
  - (c) Your linking transceiver to the specified destination linking transceiver through the intermediate controllers and linking transceivers.
  - (d) From the destination linking transceiver to the associated controller.
  - (e) From the destination controller to the desired repeater.
  
6. We have configured the INTERTIE system so that all of the UHF linking transceivers are in an operational state with the receivers and transmitters in a "hot" condition awaiting DTMF tones or voice transmissions which are then passed to the associated controller and onward as required. Thus, we have created a UHF backbone communications circuit, which runs from Morris, VE4CDN, through to Dryden, VE3DRY. There will also be "off shoots" installed in the future such as Selkirk VE4MBR, which will be connected in a similar fashion.
  
7. Our configuration for the moment, has everything connected together so that transmissions on one repeater will be heard on all repeaters connected to the system. This method of operation allows our technical members to carry out an extensive evaluation of the over-all system and correct any faults that may become apparent. For example, a minor amount of audio distortion at Morris will be amplified down the system and become unbearable at Dryden.
  
8. Eventually, we expect that the NW Ontario system (including VE4FAL) will remain connected. This approach is being taken because the system covers a large geographical area with a minimum number of Radio Amateurs. It also increases the chances that someone will be available should an emergency occur, which is important to the clubs in that area. The Manitoba system has the rural areas normally connected with the City of Winnipeg isolated. This is because of the heavy Amateur Radio population in Winnipeg in that the system would become too congested for use. However, it should be noted that the configurations are not cast in stone at this point in time, experience and user requirements will dictate the form it takes.
  
9. There will be times when special temporary configurations take place. This will be in times of emergencies, public service, community events, etc.

VE4ABC this is  
VE3XYZ over

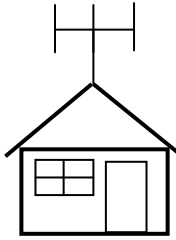

VE4ABC this is VE3XYZ  
Good Morning

FIGURE 1

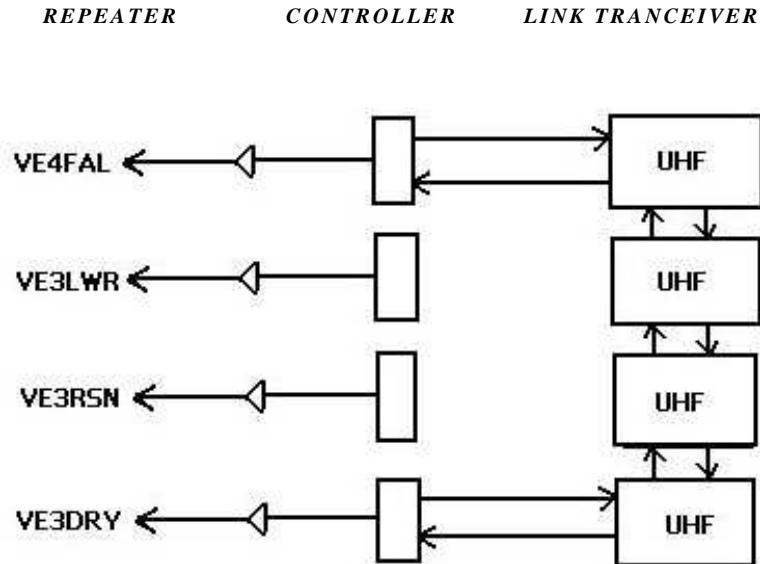

Note – The path from VE4ABC to VE3XYZ is through VE4FAL repeater, controller and linking transceiver then through the VE3LWR, VE3RSN and VEDRY link transceivers and finally the VE3DRY controller and repeater. Please note that in this instance there is no connection from VE3LWR and VE3RSN repeaters to the linking, as this was not included with the linking commands that were given.

## An explanation of "user" codes ...

### GENERAL...

1. All commands to a local repeater must be prefixed with a star (\*), ie - **\*402/(702)**.
2. All commands to a distant controller must be prefixed with a "#" followed by the two digit "link prefix code", ie - **#40**, then enter your next code sequence.
3. All commands to a distant repeater through a distant controller do not require the star, ie – **402/(702)**.
4. All command codes must be sent with no more than one second between digits. If a mistake is made or the command does not take, wait several seconds and start the sequence over again. Unless you have a good memory, it is a good idea to have the "users Crib Sheet" with the codes in front of you.
5. During any controller command sequence, all of the DTMF tones are muted to all of the transmitters on the system. Only the first forty milliseconds of the "\*" or the "#" will be heard, thus reducing unwanted transmissions to a minimum.

6. Before starting a control sequence, *always* announce your intent, for example- "*This is VE4--- controlling VE4MAN*" or "*This is VE4- controlling Starbuck*".
7. When you are finished, always return the system to its original configuration but after you have checked to ensure that someone else is not in need of the set up you have made, If the control is passed to someone else, then it is their responsibility to restore the system to normal.
8. On occasions you will hear a control operator on the system carrying out maintenance, etc. Please allow them to pursue their objective without interference and until they clear the system.
9. Because of technical problems we request that you do not use the UHF linking equipment for any purpose although you may hear a control operator entering the system through the UHF for maintenance purposes.
10. Please remember that when you key up a repeater on the system that you are probably keying up a number of repeaters and UHF transmitters at the same time. When the system is full up, one "**kerchunk**" will key up about 30 transmitters.
11. Another point to remember is that should there be a need to open the system between Manitoba and Ontario, this will be done at Falcon Lake, VE4FAL, using **LINK TWO**. This will disconnect/connect the UHF transceiver serving Milner Ridge, VE4MIL from the associated controller. Thus, the Manitoba system and the Ontario systems will operate independently when **LINK TWO** at Falcon Lake is opened.
12. Most of the older VHF/UHF transceivers do not have a four column key pad, This should not interfere with most "**user**" codes, although some telemetry codes will not be available to you, for example "**71A**" which is the Link 1 test command.

## Configuration Codes

### LINK PREFIX

This is a discrete code assigned to each of the Palomar controllers. It consists of two-digits preceded by the "#" and is site programmable. We have assigned the codes so that all of Manitoba start with #4 (relating to VE4) with Falcon Lake being #40.

The codes are then assigned in a cumulative fashion, westward, with Minnedosa being #50, and leaving space for future controllers, On a similar basis, NW Ontario is assigned #3 (relating to VE3/VA3) and with Kenora becoming #30 and the working southeast leaving space for future installations. The link prefix assignments are detailed in the "*User Codes - Crib Sheet*" and also the "*Repeater Data Sheets*", attached.

The "*Link Prefix Code*" is your access code to a distant controller as you will not be able to perform any control functions until the code has been accepted by the controller. Consider it the same as an "*area code*" in your telephone system.

When you have entered this code properly, you will receive a "*dial tone*" as a response, This sounds similar to a telephone system "*dial tone*" and confirms that the controller has received the command, Once you hear the dial tone you have eight seconds to begin entering additional command codes.

Should the controller be in use and not available to you, the response will be a different tone similar to a telephone "*busy signal*", The busy signal has a duration of ten seconds and should the distant control operator release the system within the ten seconds, then the busy signal will change to a dial tone and you can carry on since control has been transferred to you.

On occasions you may hear different tones superimposed on the dial tone for the Link Prefix code answer back. If you hear a series of "*beeps*" along with the dial tone this will signify that the attached repeater is disconnected from the controller, while a series of "*beep beeps*" will signify that the link you are entering the controller on is actually disconnected. In both cases it will be necessary to restore the appropriate connection.

### EXAMPLE

You are in the Minnedosa area and you desire to connect to the controller at Kenora. We are assuming that the Minnedosa repeater is connected to the intertie system.

**ANNOUNCE->KEY IN #30->** <-**DIAL TONE** (you are connected to Kenora controller).  
 <-**DIAL TONE =BEEPS** (connected to Kenora controller but VE3LWR is disconnected)  
 <-**DIAL TONE-BEEP BEEPS**(connected to Kenora controller but its Link 2 is open)

## LINK CONNECT AND DISCONNECT

Each of the Palomar controllers has a number of ports that are used to connect to the UHF linking transceivers, These are used for linking the various repeaters together and the links are identified numerically. Some controllers are only using one link at the moment while others are using, two, three or four. The specific assignments are identified in the "*User Codes-Crib Sheet*" and also "*Repeater Data Sheets*", For example, VE4WPG at Winnipeg uses four links, *link 1* to the VE4VJ repeater, *link 2* to Starbuck, *link 3* to Milner Ridge and *link 4* to Gimli, while at Sioux Narrows, *link 1* is to Kenora, *link 2* to Blackhawk and *link 3* to Dryden,

### Link Designations: (Example)

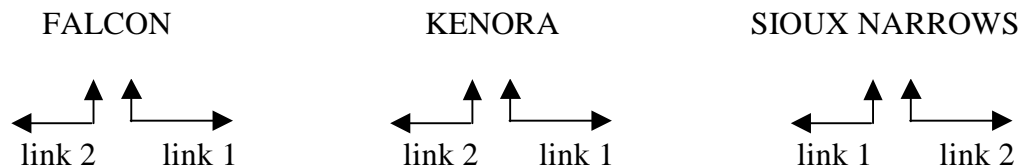

**Figure 2**

There is a variation to this. Some repeater sites do not have a Palomar controller and we are using remote Palomar controllers as the switching agent. This is true for Sioux Lookout which is switched at Dryden and Winnipeg VE4VJ (UHF) is switched at Winnipeg. Thus we can switch the three aforementioned repeaters in and out of the Intertie system as desired.

The linking codes are as follows:

<b>701</b> – Connects Link 1	<b>710</b> – Disconnects Link 1
<b>702</b> – Connects Link 2	<b>720</b> – Disconnects Link 2
<b>703</b> – Connects Link 3	<b>730</b> – Disconnects Link 3
<b>704</b> – Connects Link 4	<b>740</b> – Disconnects Link 4

(Please note the numerical relationship with these codes, ie **701 / 710** is link 1)

When you have entered a linking code you will receive an answer back as a "*beep*". This signifies that the code has been entered properly and the controller has been configured as desired. Please remember that when entering these codes to your local controller they must be prefixed with the "\*" but the "\*" is not required for a distant controller.

At some locations we have programmed these codes in the form of a macro. This allows us to join several codes together and improve the answer back, Thus, when you use 401, for example on Starbuck, VE4MAN, it will perform the 701 function and answer back on CW as "*LI on int 2 3 4*" or in voice "*link 1 connected int 2 3 4*" instead of the "*beep-beep*". (Int indicates that the associated repeater is connected internally to the controller). This will provide you with a positive answer back and that Link 1 is actually connected to VE4MAN and Links 2, 3 and 4. Should the controller be configured differently, then, the answer back will reflect the variation. Your repeater data sheets will identify where the macros have been installed and where the voice cards are available. We expect that all sites will be equipped with this macro and further variations in the future along with voice cards.

## EXAMPLES

You are in the Sioux Narrows area and you desire to re-connect the Ontario segment with the Manitoba segment. We are assuming that the Sioux Narrows repeater is connected to the Intertie system (Ontario segment) and link 2 at Falcon Lake is open to Milner Ridge.

**ANNOUNCE**->KEY IN **#40**->DIAL TONE->KEY IN **702**-><-BEEP BEEP

OR

KEY IN **402**-><-L2 ON INT 1 (CW)

<-LINK 2 CONNECTED 1 (VOICE)

You are in Minnedosa and the controller has been disconnected from the Intertie system and you wish to re-connect to the system.

**ANNOUNCE**->KEY IN **\*701**-><-BEEP BEEP

OR

KEY IN **\*401**-><-L1 ON INT (CW)

<-LINK 1 CONNECTED INT (VOICE)

## REPEATER CONNECT AND DISCONNECTED

There are two codes available that will connect or disconnect a repeater from the associated controller. This is quite useful during emergencies, public service events, etc where only local coverage is required. Disconnecting a repeater from the controller will not interfere with the normal operation of that controller and therefore the overall Intertie system is not affected. The codes are:

**506** - Connects a repeater to the associated controller.

**505** - Disconnects a repeater from the associated controller.

## EXAMPLES-

You are in the Milner Ridge area and you wish to disconnect the Milner Ridge repeater from the Milner Ridge controller.

**ANNOUNCE**->KEY IN **\*505**-><BEEP BEEP

## Telemetry Codes

There are three different groups of codes within the Telemetry codes. These are "information" codes that provide such information as the time of day, controller configuration data and message buffers. Voice response is only available at those sites equipped with voice cards, refer to the "*Repeater Data Sheets*".

### INFORMATION

**09A/099D** -This code provides a **LOCATION** message with **09A** being CW and **099D** being a voice response. The response is site programmable. In the case of Kenora, VE3LWR, the response has been factory programmed as "Lake of the Woods Amateur Radio Society VE3LWR Kenora", while the CW version is "Kenora".

**861/8661** - With the **861** code the controller will respond with the **TIME of day** (local) in the 12 hour format using CW, while **8661** will provide the same information using voice.

**862/8662** - With the **862** code the controller will respond with the **TIME** of day (local) in the 24 hour format using CW while **8662** will provide the same information using voice.

**863** - With the **863** code the controller will respond with the **DATE** using CW.

**864/8663** - With the **864** code the controller will respond with the **DAY** of the week using CW while **5663** will provide the same information using voice.

### CONFIGURATION DATA

**71A / 711A** - With the **71A** code the controller will respond with the status of its **LINK 1** using CW, ie whether the link is closed or open, while **711 A** will provide the same information using voice.

**72 A / 722A** -With the **72A** code the controller will respond with the status of its **LINK 2** using CW ie whether the link is closed or open, while **722A** will provide the same information using voice.

**73A / 733A** -With the **73A** code the controller will respond with the status of its **LINK 3** using CW ie whether the link is closed or open, while **733A** will provide the same information using voice.

**74A / 744A** -With the **74A** code the controller will respond with the status of its **LINK 4** using CW ie whether the link is closed or open, while **744A** will provide the same information using voice.

**04D/099A** - With the **04D** code the controller will respond with the status of its associated **REPEATER**, whether it is connected to the controller and also to which links it is connected to, using CW, while **099A** will provide the same data using voice.

**018** - When the **018** code is used on your local controller it will respond with the **IDENTIFIER**, ie if you commanded the Falcon Lake controller it will respond with "VE4FAL"using CW. There is no voice option.

**019** - The **019** code is used on **DISTANT** controllers to interrogate a units **IDENTIFIER**. Since you are commanding a distant controller it will be necessary to use the "Link Prefix" code ahead of the **019**. There is no voice option.

## **BUFFERS**

There are a total of twenty voice message buffers available to us which can contain a maximum of sixteen words each. We can program each of these buffers with a string of voice words to create a phrase or a sentence. We have a library of about 240 words which includes numerals and all letters of the alphabet. Each buffer can be brought up on demand or scheduled to make an announcement at any specific interval. We have made very little use of this option because the installing program is very time consuming but we are in the process of setting up a computer program to make the entries very simple. Eventually, you will be hearing scheduled voice messages such as "MRS meeting April 23" or "Net Sunday nights at 7:30 PM", etc.

## Some general rules for operating on a repeater ....

1. If you are a new Radio Amateur or using a different repeater for the first time, it is best to monitor for a short while to determine the pattern used. Most repeater protocol is very similar but in some cases a repeater may be established for a particular purpose such as a DX club, satellite, etc. In addition, some repeaters require a tone for access purposes.
2. Although it varies from repeater to repeater, it is usual to announce yourself, if you wish to make a contact, i.e.. "This is VE---- on frequency" or "VE ----- monitoring".
3. Once you have established a contact, it is necessary in Canada to identify yourself at the start of a QSO (conversation), at the end and at least every 30 minutes. In practice, it usually happens more often, which is preferable.
4. Always allow a break in your transmission to allow other Amateurs to announce themselves. This is especially true for emergencies. Most repeaters have a courtesy beep for this purpose. The Palomar units, which we have, provide a beep-bop depending upon the status of the linking system. Therefore, pause or wait for the *beep-bop* and then commence your transmission.
5. Most repeaters have a timer, that will turn the transmitter off after about three minutes. This is designed to keep each transmission short and allow a station with an emergency to access the repeater. So, if your transmission is too long you will be cut off after about three minutes, but not to worry, the repeater will restore itself after you stop transmitting.
6. When you are transmitting, you must remember that you are probably being monitored by not only a number of other Amateurs but also by non-Amateurs with scanners and other types of monitors.
7. Keep the output power on your transmitter to a minimum level consistent with good communications. This will help eliminate interference to distant repeaters or other stations.
8. Sometimes, your favorite repeater is busy but you wish to QSO with someone else. In that case make a quick arrangement with your partner and QSY (change frequency) to another repeater or a simplex frequency. There are a number of simplex frequencies with the common one being 146.52 MHz. To break into a conversation wait until there is a lull in the exchange and **announce your presence by giving your call sign quickly and only once after a station stops talking** but before the courtesy beep. Please **do not** demand a "*BREAK*".
9. It is not polite to break into a QSO unless you have something to add. Think of a QSO as a person to person conversation. Please do not interrupt unless it is important.

10. During commuter rush hours, there are some Amateurs who cannot use their equipment at other times for various reasons, so allow them some time to operate.
11. It is considered good practice to **not** transmit subject matter concerning **Religion, Politics and certainly no profanity, personal or business dealings.**
12. Some repeaters are equipped with a "**phone patch**". This is a device which connects a repeater to a community telephone system by an access code which varies from repeater to repeater. The access codes for connection and disconnection are shown on the attached repeater data sheets. Please **do not** release the **codes** or **any other codes "over the air"** as it could precipitate a lot of problems. Should someone on frequency wish to make a phone-patch but for whatever reason does not have the codes, offer to make the connection for them but you are pretty well responsible for what is said. In that vein, para 11, above does apply. Do not use a "**phone-patch**" to circumvent long distance toll charges, this is definitely not permitted excepting under declared emergencies.
13. On occasions you will hear someone on the repeater asking for assistance, directions or whatever. Please take a minute to reply to the station. Our policy is to assist wherever possible in keeping with our mandate. You might also identify points of interest, etc.. all to the common good.
14. We do have emergency conditions from time to time on one or more repeaters. Under those circumstances, pay close attention to the control operator and follow the instructions, which will be announced quite frequently. There are also special exercises which take place and the same rules apply.
15. **Remember** -- Our repeater installations took a lot of time and energy on the part of a few individuals notwithstanding a lot of money. Also to acknowledge is the valuable cooperation received from a number of outside agencies that have made the system possible. Everyone will be happy to see you use the repeater to its full advantage on as many occasions as possible. **Support your local Repeater Group.**

--ENJOY--

## Your participation in emergencies ....

Amateur Radio operators have historically provided valuable assistance during emergencies. There are quite a number of them on record in our area, but the Dryden air crash, Winnipeg flood and the Grassy Narrows O.P.P. incident exemplify how we can provide meaningful assistance. Other activities include the "Severe Weather Watch" program and the reporting of highway accidents or problems. Excepting for the latter, the emergencies are usually handled under a controlled environment with the repeater/s closed for all usual activities. A "**Net Control**" operator is established and that person directs the movement of communications. The degree of the emergency dictates the flow of non-essential traffic. Participation in the emergency is also relative to the type of emergency and you may or may not be required. In order to provide the net control operator the maximum assistance, it is best to monitor the activities and be ready to help when the request reaches you.

## Your participation in highway accidents or other incidents ....

Quite often, in our travels, we come across accidents or other incidents where assistance is required from one or more public service agencies. Experience has shown that we can be of considerable assistance under these circumstances but we do not have a control operator to so we are on our own. Therefore, the following tips are provided:

1. Remain calm.
2. Check to see if you have a repeater available with a phone patch that will provide adequate communications (voice communications have to be reasonably good for the phone patch to work properly). If a **phone patch** is not available is there someone who can "*third party*" essential information ("*third party*" transfer should be avoided, if possible, to avoid errors).
3. Do you have the "**phone patch**" *access codes*. If not, is there someone available to bring up the patch for you. It is advisable to keep a list of "**phone patch**" *access codes* in your vehicle or with your credit cards as we tend to forget them when under pressure.
4. Gather up as much information as you can, i.e.:
  - Highway number and approximate location (reference to another highway or lake, etc.).
  - Direction of travel, passing lane, driving lane or shoulder.
  - How many vehicles, is traffic blocked in any way.
  - Are there any injuries, how bad?
  - Is there a fire or a chemical/fuel spill.
5. If more information is required, the dispatcher will request it and may ask you to stay on line.
6. Announce on the repeater that you have an emergency.
7. Key in the "**phone patch**" access code and **911** or your local emergency number.
8. Advise the dispatcher that you are an Amateur Radio Operator and you have an accident to report.

**Here is an example:**

“This is VE----. I am an amateur Radio Operator reporting a two-car accident on highway 17 westbound, about 5 miles west of highway 71 intersection. The westbound lane is blocked and there are slight injuries only.”

9. Keep your report brief and to the point.
10. If possible remain at the scene until an emergency vehicle has arrived.

**SIMPLEX FREQUENCIES (in MHz)**

<b>146.52</b>	146.535	146.55	146.565	146.58
146.595	147.42	147.435	147.45	147.465
147.48	147.495	147.51	147.525	147.54
147.555	147.57	147.585		

Note 1 - **146.52Mhz** is considered the National Calling frequency.

Note 2 - Other simplex frequencies exist but they may be a repeater input/output frequency and are not listed here.

DO NOT USE SHORTENED CALLS BUT DO USE THE STANDARD PHONETICS WHEN CONDITIONS ARE POOR OR OTHERWISE NECESSARY (i.e. Alpha, Bravo, Charlie, etc.). REFRAIN FROM USING CALLS LIKE 3ABC. ALWAYS USE VA3ABC OR VA3 ALPHA, BRAVO, CHARLIE.

**JAMMERS** - On occasion you will hear strange sounds from a repeater. This may, be in the form of a continuous carrier, tones, music, vulgarity or other types of interference. The person originating this interference generally has a personal problem. They do not get their "*kicks*" from creating the QRM, but rather the reaction. The best approach is to **ignore the problem** and carry on as normal. Keep a record of times, nature of the QRM and if you have a beam, take a bearing. Refer your records to your repeater trustee.

*A wise man once said:*

**“REMEMBER, THIS IS ONLY A HOBBY”**

**REPEATER DATA BASE**  
**FIGURE 3**

VE3DRY-	147.255+	-DRYDEN
VA3DIS -	147.375+	-Dryden(IRLP 2739)
VA3IGN-	147.18+	-Ignace(IRLP 2414)
VA3BPL-	145.425-	-BEARPAW
VE3VBY-	145.31-	-CAMP ROBINSON
VA3EOE-	146.56	-Ear Falls(IRLP 2468)
VE3LWR-	147.03-	-KENORA
VE3YQK -	146.91-	-Kenora(IRLP 2949)
VE3RBK-	147.06+	-Blackhawk
VE3RLC-	146.82-	-Fort Frances
VE3BVC-	146.57	-Fort Frances(IRLP 2509)
VE3RIB-	147.12+	-Atikokan(IRLP 2768)
VE3RLD-	147.00+	-Red Lake
VE3RSN-	145.17-	-SIOUX NARROWS
VE3JJA-	146.58	-Sioux Narrows(IRLP 2015)
VE3YXL-	146.85-	-SIOUX LOOKOUT
VA3SLT-	147.315+	-Sioux Lookout(IRLP 2590)
VE3UPP-	145.47-	-Upsala
VA3LU-	145.45-	-Thunder Bay(IRLP 2000)
VE4ARM-	146.91-	-Austin
VE4BMR-	147.03-	-Baldy Mountain
VE4BVR-	147.24+	-Russell
VE4CDN-	145.27-	-MORRIS
VE4DPN-	146.64-	-Dauphin
VE4EMB-	147.36+	-HADISHVILLE
VE4FAL-	146.64-	-FALCON LAKE
VE4FFR-	146.94-	-Flin Flon
VE4GIM-	146.85-	-GIMLI
VE4LDR-	146.97-	-Lundar
VE4MAN-	146.61-	-STARBUCK
VE4MBR-	147.06+	-SELKIRK
VE4MIL-	145.21-	-MILNER RIDGE
VE4HS-	146.88-	-BRUXELLES
VE4PAS-	145.35-	-The Pas
VE4PTG-	147.165+	-Portage La Prairie
VE4SHR-	146.70-	-Ashern
VE4SSR-	145.45-	-Swan River
VE4TED-	146.73-	-BRANDON
VE4VJ-	443.50+	-WINNIPEG
VE4WOD-	145.29-	-Woodridge
VE4WPG-	147.39+	-WINNIPEG
VE4WRS-	145.45-	-Winnipeg(IRLP 1066 / Autopatch)

NOTES - FIGURES 3 & 4

1. - Locations in **capitals** indicate repeater Palomar controlled and repeater data sheets are attached for these facilities.
2. - Solid lines indicate facility in service.
3. - Broken line indicates future facility.
4. - DAR"C" system is hard linked (VE4LDR to VE4SSR). VE4DPN is available on demand. VE4PAS / VE4FFR will also be on demand.

Manitoba Repeaters

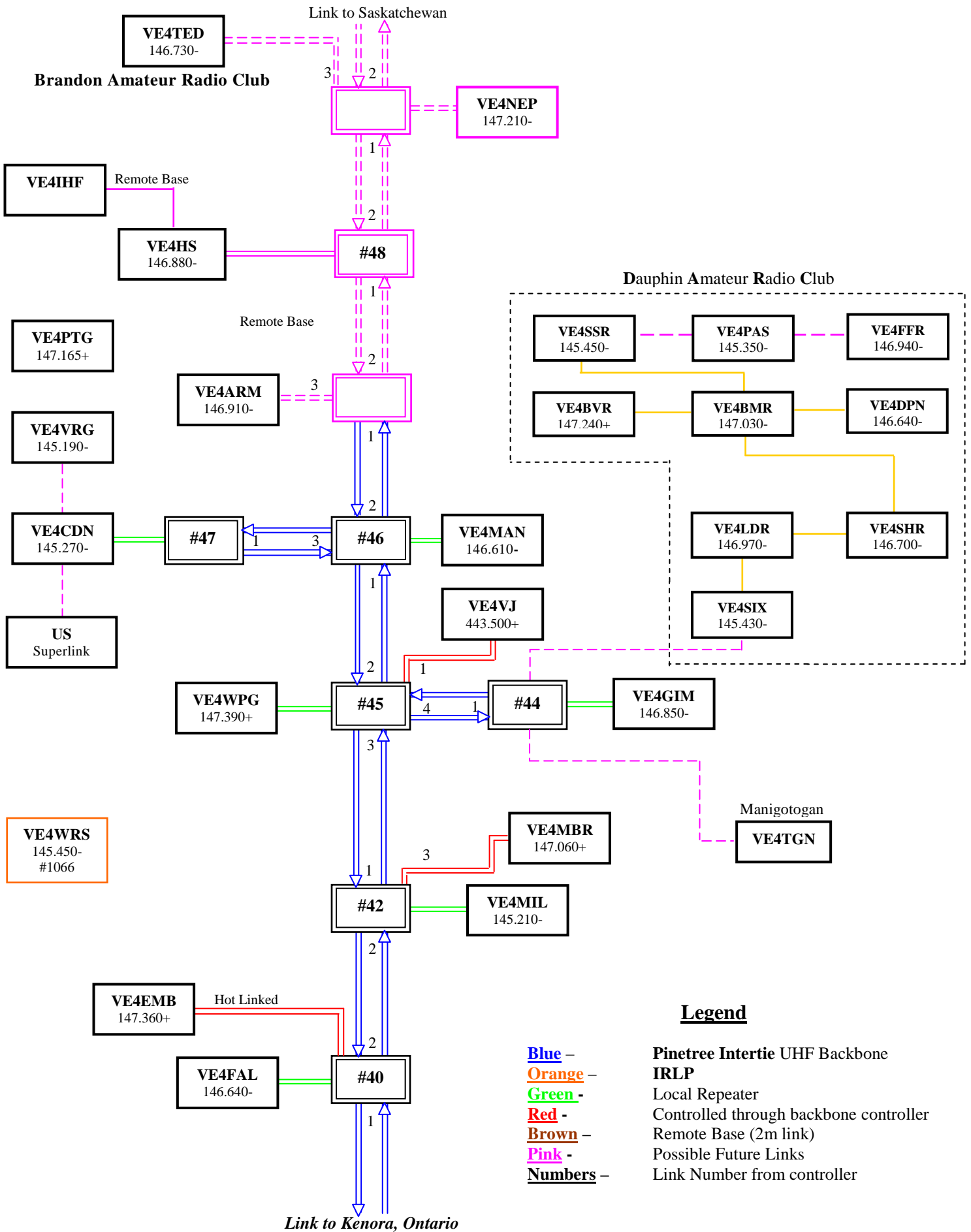

**Northwest Ontario Repeaters**

*Link to Falcon Lake, Manitoba*

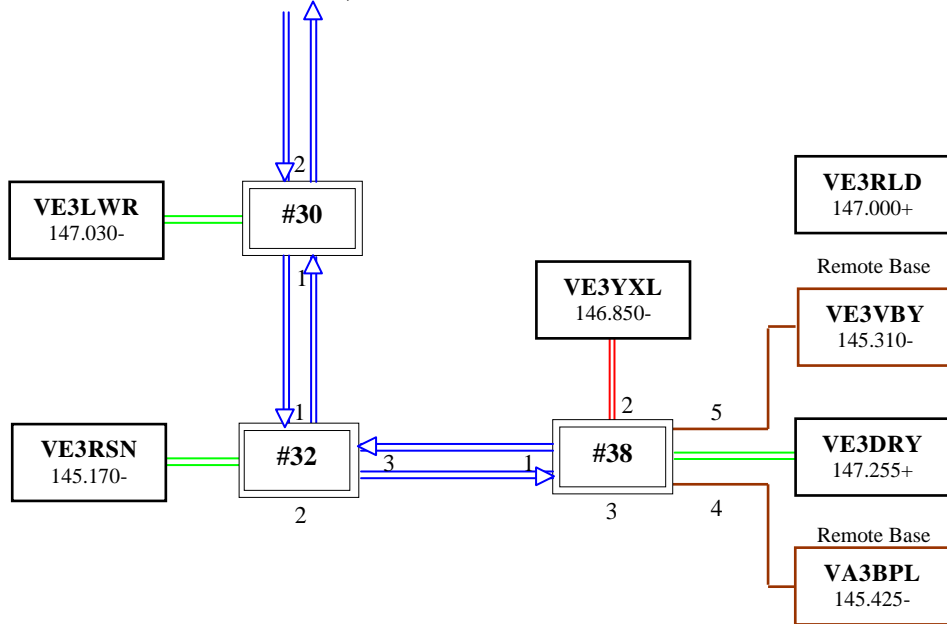

**VE3RBK**  
147.060+

**VE3RLC**  
146.820-

**VE3UPP**  
145.470-

**VASLT**  
147.315+  
#2590

**VA3IGN**  
147.180+  
#2414

**VE3RIB**  
147.120+  
#2768

**VE3JJA**  
146.580  
#2015

**VE3BVC**  
146.570  
#2509

**VA3DIS**  
147.375+  
#2739

**VE3YQK**  
146.910-  
#2949

**VA3LU**  
145.450-  
#2000

**VA3EOE**  
146.56  
#2468

**Legend**

- Blue** – Pinetree Intertie UHF Backbone
- Orange** – IRLP
- Green** – Local Repeater
- Red** – Controlled through backbone controller
- Brown** – Remote Base (2m link)
- Plum** – Local
- Numbers** – Link Number from controller

## Northwestern Ontario Repeaters

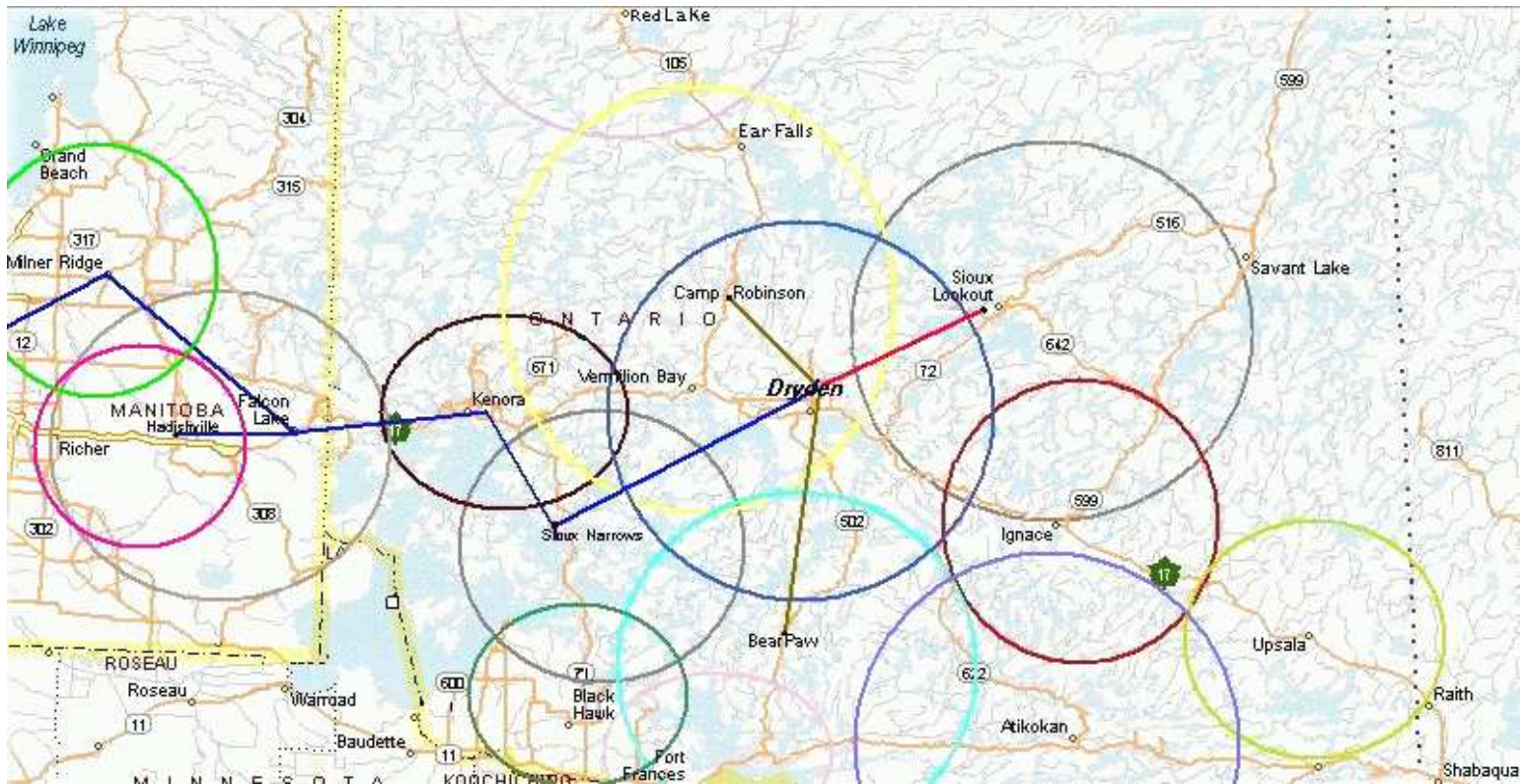

### Legend

- Blue** – Pinetree Intertie UHF Backbone
- Red** - Controlled through backbone controller
- Brown** – Remote Base (2m link)
- Coloured Rings** – Indicate approximate range of repeater

BEARPAW, ON

VA3BPL

<p>FREQUENCY – 144.825 / <u>145.425</u></p>	<p>OFFSET – MINUS ( - 600 Hz)</p>
<p>OWNER – A.R.S.D</p>	<p>CONTACT – GARY McNALLY, VE3MOR (807)-938-1034 SCOTT MOODY, VA3EXT (807)-937-2062</p>
<p>LOCATION – BEARPAW LAKE , 50 MILES SOUTH OF DRYDEN ON HIGHWAY 502</p>	
<p>PHONE PATCH – Not Available</p>	
<p style="text-align: center;"><b><u>CODES</u></b></p> <p>FOR LINKING PURPOSES, THIS REPEATER IS CONNECTED TO THE <i>LINK COMMUNICATIONS</i> RLC-3 CONTROLLER IN DRYDEN, <b>VE3DRY</b> REPEATER AS A REMOTE BASE.</p> <p>TO <b>CONNECT</b> OR <b>DISCONNECT</b> THE BEARPAW, <b>VA3BPL</b> REPEATER TO THE DRYDEN REPEATER USE <b><u>CODES</u></b> *704 – ON or *740 - OFF THROUGH THE <b>VE3DRY</b> CONTROLLER</p>	

IGNACE, ON

VA3IGN

<p>FREQUENCY – 147.78 / <b><u>147.18</u></b></p>	<p>OFFSET – POSITIVE ( + 600 Hz)</p>
<p>OWNER - ARSD</p>	<p>CONTACT – WALLY DAVENPORT, VA3WGD (807)-934-2432 RICK ASHTON, VA3RGA (807)-937-5721</p>
<p>LOCATION – IGNACE PUBLIC SCHOOL, DOWNTOWN IGNACE.</p>	
<p>PHONE PATCH – Not Available</p>	
<p style="text-align: center;"><b><u>CODES</u></b></p> <p><b>IRLP # 2414</b></p> <p><b>*701 –IRLP - ON</b> <b>*710 –IRLP- OFF</b></p> <p style="text-align: center;"><i>No Linking at this time</i></p> <p style="text-align: center;"><b><u>TELEMETRY</u></b></p> <p>Signal Test.....<b>A*</b> (Talk into the DVR and it will play back) Keypad Test..... <b>B</b> (Key in string of numbers and it reads back) Time.....<b>C</b> (Tells the time in Female voice) Temperature.....<b>C1</b> (Tells the Outside Temperature)</p>	

# VA3IGN Repeater IRLP Node # 2414

**147.180+**

Autopatch Access & Speed Dial .....	None
Keypad Test .....	B (Key in string of numbers an it reads back)
Signal Test .....	A* (Talk into the DVR and it will play back)
Time .....	C (Tells the time in Female voice)
Temperature.....	C1 (Tells the outside temperature)
Repeater-IRLP(ON).....	*701(Connects repeater and IRLP link)
Repeater-IRLP(OFF).....	*710(Disconnects repeater and IRLP link)

## **IRLP**

The controller is always connected to the IRLP node.

Repeater-IRLP(ON), \*701 - Connects repeater and IRLP link.

Repeater-IRLP(OFF), \*710 - Disconnects repeater and IRLP link and sends 73 to IRLP to disconnect from any node or reflector.

SIOUX NARROWS, ON

VE3RSN

<p>FREQUENCY – 144.57 / <u>145.17</u></p>	<p>OFFSET – MINUS ( - 600 Hz)</p>												
<p>OWNER – L.O.W.A.R.S.</p>	<p>CONTACT – WOODY LINTON, VE3JJA (807)-226-2665</p>												
<p>LOCATION – ON THE BELL CANADA TOWER, EAST SIDE OF HWY 71, 4 MILE SOUTH OF SIOUX NARROWS, ON.</p>													
<p>PHONE PATCH – Not Available</p>													
<p style="text-align: center;"><b><u>CODES</u></b></p> <p>#32 - Link Prefix</p> <p>505 - Disconnects Repeater from links 506 - Re-connects Repeater to links</p> <table style="width: 100%; border: none;"> <tr> <td style="width: 50%;">701 – LINK 1 to Kenora,</td> <td style="width: 50%;">VE3LWR, - <b>ON</b></td> </tr> <tr> <td>710 – LINK 1 to Kenora,</td> <td>VE3LWR, - <b>OFF</b></td> </tr> <tr> <td>702 – LINK 2</td> <td>- <b>ON</b></td> </tr> <tr> <td>720 – LINK 2</td> <td>- <b>OFF</b></td> </tr> <tr> <td>703 – LINK 3 to Dryden,</td> <td>VE3DRY, - <b>ON</b></td> </tr> <tr> <td>730 – LINK 3 to Dryden,</td> <td>VE3DRY, - <b>OFF</b></td> </tr> </table> <p style="text-align: center;"><b><u>TELEMETRY</u></b></p> <p style="text-align: center;"><u>CW</u></p> <p>09A-----LOCATION MESSAGE 861-----TIME - 12 HOUR FORMAT 862-----TIME - 24 HOUR FORMAT 863-----DATE 864-----DAY OF WEEK 71A-----LINK 1 TEST 72A-----LINK 1 TEST 04D-----REPEATER TEST 018-----START LOCAL IDENTIFIER 019-----START REMOTE IDENTIFIER</p>		701 – LINK 1 to Kenora,	VE3LWR, - <b>ON</b>	710 – LINK 1 to Kenora,	VE3LWR, - <b>OFF</b>	702 – LINK 2	- <b>ON</b>	720 – LINK 2	- <b>OFF</b>	703 – LINK 3 to Dryden,	VE3DRY, - <b>ON</b>	730 – LINK 3 to Dryden,	VE3DRY, - <b>OFF</b>
701 – LINK 1 to Kenora,	VE3LWR, - <b>ON</b>												
710 – LINK 1 to Kenora,	VE3LWR, - <b>OFF</b>												
702 – LINK 2	- <b>ON</b>												
720 – LINK 2	- <b>OFF</b>												
703 – LINK 3 to Dryden,	VE3DRY, - <b>ON</b>												
730 – LINK 3 to Dryden,	VE3DRY, - <b>OFF</b>												

DRYDEN, ON

VE3DRY

<p>FREQUENCY – 147.855 / <u>147.255</u></p>	<p>OFFSET – POSITIVE ( + 600 Hz)</p>																				
<p>OWNER – A.R.S.D</p>	<p>CONTACT – GARY McNALLY, VE3MOR (807)-938-1034</p>																				
<p>LOCATION – FIVE MILES NORTH OF THE CITY OF DRYDEN ON HWY 601</p>																					
<p>PHONE PATCH – See attached</p>																					
<p style="text-align: center;"><b><u>CODES</u></b></p> <p><b>#38</b> - Link Prefix</p> <p><b>505</b> - Disconnects Repeater from links  <b>506</b> - Re-connects Repeater to links</p> <table data-bbox="267 1186 1055 1554"> <tr> <td><b>701</b> – LINK 1 to Sioux Narrows,</td> <td>VE3RSN, - <b>ON</b></td> </tr> <tr> <td><b>710</b> – LINK 1 to Sioux Narrows,</td> <td>VE3RSN, - <b>OFF</b></td> </tr> <tr> <td><b>702</b> – LINK 2 to Sioux Lookout,</td> <td>VE3YXL, - <b>ON</b></td> </tr> <tr> <td><b>720</b> – LINK 2 to Sioux Lookout,</td> <td>VE3YXL, - <b>OFF</b></td> </tr> <tr> <td><b>703</b> – LINK 3</td> <td>- <b>ON</b></td> </tr> <tr> <td><b>730</b> – LINK 3</td> <td>- <b>OFF</b></td> </tr> <tr> <td><b>704</b> – REMOTE BASE to BearPaw,</td> <td>VA3BPL, - <b>ON</b></td> </tr> <tr> <td><b>740</b> – REMOTE BASE to BearPaw,</td> <td>VA3BPL, - <b>OFF</b></td> </tr> <tr> <td><b>705</b> – REMOTE BASE to Camp Robinson,</td> <td>VE3VBY, - <b>ON</b></td> </tr> <tr> <td><b>750</b> – REMOTE BASE to Camp Robinson,</td> <td>VE3VBY, - <b>OFF</b></td> </tr> </table> <p style="text-align: center;"><b><u>TELEMETRY</u></b></p> <p>Signal Test.....<b>A*</b> (Talk into the DVR and it will play back)          Keypad Test.....<b>B</b> (Key in string of numbers and it reads back)          Time.....<b>C</b> (Tells the time in Female voice)          Temperature.....<b>C1</b> (Tells the Inside &amp; Outside Temperature)          Temperature.....<b>C2</b> (Toggles the Inside, Outside, Hi &amp; Low )</p>		<b>701</b> – LINK 1 to Sioux Narrows,	VE3RSN, - <b>ON</b>	<b>710</b> – LINK 1 to Sioux Narrows,	VE3RSN, - <b>OFF</b>	<b>702</b> – LINK 2 to Sioux Lookout,	VE3YXL, - <b>ON</b>	<b>720</b> – LINK 2 to Sioux Lookout,	VE3YXL, - <b>OFF</b>	<b>703</b> – LINK 3	- <b>ON</b>	<b>730</b> – LINK 3	- <b>OFF</b>	<b>704</b> – REMOTE BASE to BearPaw,	VA3BPL, - <b>ON</b>	<b>740</b> – REMOTE BASE to BearPaw,	VA3BPL, - <b>OFF</b>	<b>705</b> – REMOTE BASE to Camp Robinson,	VE3VBY, - <b>ON</b>	<b>750</b> – REMOTE BASE to Camp Robinson,	VE3VBY, - <b>OFF</b>
<b>701</b> – LINK 1 to Sioux Narrows,	VE3RSN, - <b>ON</b>																				
<b>710</b> – LINK 1 to Sioux Narrows,	VE3RSN, - <b>OFF</b>																				
<b>702</b> – LINK 2 to Sioux Lookout,	VE3YXL, - <b>ON</b>																				
<b>720</b> – LINK 2 to Sioux Lookout,	VE3YXL, - <b>OFF</b>																				
<b>703</b> – LINK 3	- <b>ON</b>																				
<b>730</b> – LINK 3	- <b>OFF</b>																				
<b>704</b> – REMOTE BASE to BearPaw,	VA3BPL, - <b>ON</b>																				
<b>740</b> – REMOTE BASE to BearPaw,	VA3BPL, - <b>OFF</b>																				
<b>705</b> – REMOTE BASE to Camp Robinson,	VE3VBY, - <b>ON</b>																				
<b>750</b> – REMOTE BASE to Camp Robinson,	VE3VBY, - <b>OFF</b>																				

# VE3 DRY Repeater

**147.255+**

Autopatch Access & Autodial.....	9 (ie: 9 937xxxx or 9 10)
Autopatch Termination .....	#
Redial Last Number .....	9*
Reverse Autopatch Answer .....	0
Emergency Speed dial Access .....	91 (Dials Emergency 911)
Signal Test .....	A* (Talk into the DVR and it will play back)
Keypad Test .....	B (Key in string of numbers and it reads back)
Time .....	C (Tells the time in Female voice)
Temperature.....	C1 (Tells the Inside & Outside Temperature)
Temperature.....	C2 (Toggles the Inside, Outside, Hi & Low )
Wind Speed & Direction.....	C4 (Tells the Wind Speed & Direction)

## Making a reverse autopatch call

Dial the repeater number 937-6441. After about two rings the repeater will answer with “ Please Enter Security Code” enter code, (*code is available from Gary McNally, VE3MOR*), and it will say “Enter Autopatch Code”. Enter a (Star) \*, the amateur’s speed dial plus (Pound)# and it will call their callsign plus ring over the phone and air. If a radio operator answers with the reverse autopatch answer number, zero(0), the repeater will say “Call Connected” and the conversation can take place. If an amateur does not answer with in a few call outs, the repeater will tell you “No Answer”. After the reverse autopatch is completed, the radio operator hangs up with the autopatch termination number (#), just like a normal autopatch.

## Emergency Speed Dials (ie 92 dials the O.P.P Comm Center)

911.....	911
0.....	Operator
1.....	911
2 .....	O.P.P Communication Center (Kenora)
3 .....	Dryden Ambulance
4 .....	Dryden Fire Department
5 .....	Dryden Hospital
6 .....	AES Weather Watch (Can-Warn)
7.....	Flight Weather Messages
8 .....	Dryden Weather Information
9 .....	Highway Conditions (November to April)

KENORA, ON

VE3LWR

FREQUENCY – 146.43 / <u>147.03</u>	OFFSET – MINUS ( - 600 Hz)																																																		
OWNER – L.O.W.A.R.S.	CONTACT – DALE MADISON, VE3EFY (807)-547-2443																																																		
LOCATION – HILLY LAKE, HIGHWAY 17 , EAST OF THE CITY OF KENORA																																																			
PHONE PATCH – UP - *789, DOWN - #																																																			
<p style="text-align: center;"><b><u>CODES</u></b></p> <p><b>#30</b> - Link Prefix</p> <p><b>505</b> - Disconnects Repeater from links  <b>506</b> - Re-connects Repeater to links</p> <table style="width: 100%; border: none;"> <tr> <td style="width: 50%;"><b>701</b> – (MACRO 401) LINK 1 to Sioux Narrows,</td> <td style="width: 50%;"><b>VE3RSN</b>, - <b>ON</b></td> </tr> <tr> <td><b>710</b> – (MACRO 410) LINK 1 to Sioux Narrows,</td> <td><b>VE3RSN</b>, - <b>OFF</b></td> </tr> <tr> <td><b>702</b> – (MACRO 402) LINK 2 to Falcon Lake,</td> <td><b>VE4FAL</b>, - <b>ON</b></td> </tr> <tr> <td><b>720</b> – (MACRO 420) LINK 2 to Falcon Lake,</td> <td><b>VE4FAL</b>, - <b>OFF</b></td> </tr> </table> <p style="text-align: center;"><b><u>TELEMETRY</u></b></p> <table style="width: 100%; border: none;"> <thead> <tr> <th style="text-align: left;"><u>CW</u></th> <th style="text-align: right;"><u>VIOCE</u></th> </tr> </thead> <tbody> <tr> <td>09A-----</td> <td>-----099D</td> </tr> <tr> <td colspan="2" style="text-align: center;">LOCATION MESSAGE-----</td> </tr> <tr> <td>861-----</td> <td>-----8661</td> </tr> <tr> <td colspan="2" style="text-align: center;">TIME - 12 HOUR FORMAT-----</td> </tr> <tr> <td>862-----</td> <td>-----8662</td> </tr> <tr> <td colspan="2" style="text-align: center;">TIME - 24 HOUR FORMAT-----</td> </tr> <tr> <td>863-----</td> <td>-----</td> </tr> <tr> <td colspan="2" style="text-align: center;">DATE-----</td> </tr> <tr> <td>864-----</td> <td>-----8663</td> </tr> <tr> <td colspan="2" style="text-align: center;">DAY OF WEEK-----</td> </tr> <tr> <td>71A-----</td> <td>-----711A</td> </tr> <tr> <td colspan="2" style="text-align: center;">LINK 1 TEST-----</td> </tr> <tr> <td>72A-----</td> <td>-----722A</td> </tr> <tr> <td colspan="2" style="text-align: center;">LINK 1 TEST-----</td> </tr> <tr> <td>04D-----</td> <td>-----099A</td> </tr> <tr> <td colspan="2" style="text-align: center;">REPEATER TEST-----</td> </tr> <tr> <td>018-----</td> <td>-----</td> </tr> <tr> <td colspan="2" style="text-align: center;">START LOCAL IDENTIFIER-----</td> </tr> <tr> <td>019-----</td> <td>-----</td> </tr> <tr> <td colspan="2" style="text-align: center;">START REMOTE IDENTIFIER-----</td> </tr> </tbody> </table>		<b>701</b> – (MACRO 401) LINK 1 to Sioux Narrows,	<b>VE3RSN</b> , - <b>ON</b>	<b>710</b> – (MACRO 410) LINK 1 to Sioux Narrows,	<b>VE3RSN</b> , - <b>OFF</b>	<b>702</b> – (MACRO 402) LINK 2 to Falcon Lake,	<b>VE4FAL</b> , - <b>ON</b>	<b>720</b> – (MACRO 420) LINK 2 to Falcon Lake,	<b>VE4FAL</b> , - <b>OFF</b>	<u>CW</u>	<u>VIOCE</u>	09A-----	-----099D	LOCATION MESSAGE-----		861-----	-----8661	TIME - 12 HOUR FORMAT-----		862-----	-----8662	TIME - 24 HOUR FORMAT-----		863-----	-----	DATE-----		864-----	-----8663	DAY OF WEEK-----		71A-----	-----711A	LINK 1 TEST-----		72A-----	-----722A	LINK 1 TEST-----		04D-----	-----099A	REPEATER TEST-----		018-----	-----	START LOCAL IDENTIFIER-----		019-----	-----	START REMOTE IDENTIFIER-----	
<b>701</b> – (MACRO 401) LINK 1 to Sioux Narrows,	<b>VE3RSN</b> , - <b>ON</b>																																																		
<b>710</b> – (MACRO 410) LINK 1 to Sioux Narrows,	<b>VE3RSN</b> , - <b>OFF</b>																																																		
<b>702</b> – (MACRO 402) LINK 2 to Falcon Lake,	<b>VE4FAL</b> , - <b>ON</b>																																																		
<b>720</b> – (MACRO 420) LINK 2 to Falcon Lake,	<b>VE4FAL</b> , - <b>OFF</b>																																																		
<u>CW</u>	<u>VIOCE</u>																																																		
09A-----	-----099D																																																		
LOCATION MESSAGE-----																																																			
861-----	-----8661																																																		
TIME - 12 HOUR FORMAT-----																																																			
862-----	-----8662																																																		
TIME - 24 HOUR FORMAT-----																																																			
863-----	-----																																																		
DATE-----																																																			
864-----	-----8663																																																		
DAY OF WEEK-----																																																			
71A-----	-----711A																																																		
LINK 1 TEST-----																																																			
72A-----	-----722A																																																		
LINK 1 TEST-----																																																			
04D-----	-----099A																																																		
REPEATER TEST-----																																																			
018-----	-----																																																		
START LOCAL IDENTIFIER-----																																																			
019-----	-----																																																		
START REMOTE IDENTIFIER-----																																																			

BLACKHAWK, ON

VE3RBK

<p>FREQUENCY – 147.66 / <u>147.06</u></p>	<p>OFFSET – POSITIVE ( + 600 Hz)</p>
<p>OWNER – R.L.A.R.C.</p>	<p>CONTACT – ED KIVIMAKI, VE3JHH (807)-274-5122</p>
<p>LOCATION – EAST OF HIGHWAY 71 AT FINLAND, 5 MILES NORTH OF EMO, ON.</p>	
<p>PHONE PATCH – Not Available</p>	
<p style="text-align: center;"><b><u>CODES</u></b></p> <p><b>Local</b></p> <p style="text-align: center;"><i>No Linking at this time</i></p>	

FORT FRANCES, ON

VE3RLC

FREQUENCY – 146.22 / <u>146.82</u>	OFFSET – MINUS ( - 600 Hz)
OWNER – R.L.A.R.C.	CONTACT – ED KIVIMAKI, VE3JHH (807)-274-5122
LOCATION – 1 MILE NORTH OF CANADAIN TIRE ON THE ONTARIO HYDRO TOWER	
PHONE PATCH – UP - *789,      DOWN - #	
<p style="text-align: center;"><b><u>CODES</u></b></p> <p><b>Local</b></p> <p style="text-align: center;"><i>No Linking at this time</i></p>	

CAMP ROBINSON, ON

VE3VBY

<p>FREQUENCY – 144.71 / <u>145.31</u></p>	<p>OFFSET – MINUS ( - 600 Hz)</p>
<p>OWNER – FRED TAYLOR, VE3ZFT</p>	<p>CONTACT – FRED TAYLOR, VE3ZFT (807)-227-5578 SCOTT MOODY, VA3EXT (807)-937-2062</p>
<p>LOCATION – CAMP ROBINSON , 25 MILES NORTH OF VERMILION BAY ON HIGHWAY 105</p>	
<p>PHONE PATCH – Not Available</p>	
<p style="text-align: center;"><b><u>CODES</u></b></p> <p>FOR LINKING PURPOSES, THIS REPEATER IS CONNECTED TO THE <i>LINK COMMUNICATIONS</i> RLC-3 CONTROLLER IN DRYDEN, <b>VE3DRY</b> REPEATER AS A REMOTE BASE.</p> <p>TO <b>CONNECT</b> OR <b>DISCONNECT</b> THE CAMP ROB, <b>VE3VBY</b> REPEATER TO THE DRYDEN REPEATER USE <b><u>CODES</u></b> *705 – ON or *750 - OFF THROUGH THE <b>VE3DRY</b> CONTROLLER</p> <p style="text-align: center;"><b><u>TELEMETRY</u></b></p> <p>Signal Test.....<b>A*</b> (Talk into the DVR and it will play back) Keypad Test.....<b>B</b> (Key in string of numbers and it reads back) Time.....<b>C</b> (Tells the time in voice)</p>	

SIOUX LOOKOUT, ON

VE3YXL

<p>FREQUENCY – 146.25 / <u>146.85</u></p>	<p>OFFSET – MINUS ( - 600 Hz)</p>
<p>OWNER – S.L.A.R.G.</p>	<p>CONTACT – ADI LINDEN, VA3ADI (807)-737-7296</p>
<p>LOCATION – 6 MILES SOUTH WEST OF SIOUX LOOKOUT, AT THE OLD RADAR BASE</p>	
<p>PHONE PATCH – Not Available</p>	
<p style="text-align: center;"><b><u>CODES</u></b></p> <p>FOR LINKING PURPOSES, THIS REPEATER IS CONNECTED TO THE <i>LINK COMMUNICATIONS</i> RLC-3 CONTROLLER IN DRYDEN, <b>VE3DRY</b> REPEATER.</p> <p>TO <b>CONNECT</b> OR <b>DISCONNECT</b> THE SIOUX LOOKOUT, <b>VE3YXL</b> REPEATER TO THE LINKING SYSTEM USE <b><u>CODES</u> 702 – ON</b> or <b>720 - OFF</b> THROUGH THE <b>VE3DRY</b> CONTROLLER</p>	

MORRIS, MB

VE4CDN

<p>FREQUENCY – 144.67 / <u>145.27</u>                  CTCSS (PL) 127.3 Hz -3A</p>	<p>OFFSET – MINUS ( - 600 Hz)</p>
<p>OWNER – M.R.S.</p>	<p>CONTACT – Technical Chairperson                  Manitoba Repeater Society                  (204)-944-1914</p>
<p>LOCATION – SOUTH END OF THE TOWN OF MORRIS</p>	
<p>PHONE PATCH – Not Available</p>	
<p style="text-align: center;"><b><u>CODES</u></b></p> <p><b>#47</b> - Link Prefix</p> <p><b>505</b> - Disconnects Repeater from links</p> <p><b>500</b> - Re-connects Repeater to links</p>	

HADASHVILLE, MB

VE4EMB

<p>FREQUENCY – 147.96 / <u>147.36</u></p>	<p>OFFSET – POSITIVE ( + 600 Hz)</p>
<p>OWNER – M.R.S.</p>	<p>CONTACT – Technical Chairperson Manitoba Repeater Society (204)-944-1914</p>
<p>LOCATION – 1 MILE SOUTH OF HADASHVILLE, 1 MILE NORTH OF HWY 1.</p>	
<p>PHONE PATCH – Not Available</p>	
<p style="text-align: center;"><b><u>CODES</u></b></p> <p>FOR LINKING PURPOSES, THIS REPEATER IS HOT-LINKED TO FALCON LAKE, <b>VE4FAL</b> REPEATER.</p> <p><i>There is no controlling of this repeater.</i></p>	

FALCON LAKE, MB

VE4FAL

<p>FREQUENCY – 146.04 / <u>146.64</u></p>	<p>OFFSET – MINUS ( - 600 Hz)</p>
<p>OWNER – L.O.W.A.R.S.</p>	<p>CONTACT – DALE MADISON, VE3EFY (807)-547-2443</p>
<p>LOCATION – SOUTH SHORE, FALCON LAKE, MB.</p>	
<p>PHONE PATCH – Not Available</p>	
<p style="text-align: center;"><b><u>CODES</u></b></p> <p><b>#40</b> - Link Prefix</p> <p><b>505</b> - Disconnects Repeater from links  <b>506</b> - Re-connects Repeater to links</p> <p><b>701</b> – (MACRO 401) LINK 1 to Kenora,                   VE3LWR, - <b>ON</b>  <b>710</b> – (MACRO 410) LINK 1 to Kenora,                   VE3LWR, - <b>OFF</b>  <b>702</b> – (MACRO 402) LINK 2 to Milner Ridge,           VE4MIL, - <b>ON</b>  <b>720</b> – (MACRO 420) LINK 2 to Milner Ridge,           VE4MIL, - <b>OFF</b></p> <p style="text-align: center;"><b><u>TELEMETRY</u></b></p> <p style="text-align: center;"><b><u>CW</u></b></p> <p>09A-----LOCATION MESSAGE  861-----TIME - 12 HOUR FORMAT  862-----TIME - 24 HOUR FORMAT  863-----DATE  864-----DAY OF WEEK  71A-----LINK 1 TEST  72A-----LINK 1 TEST  04D-----REPEATER TEST  018-----START LOCAL IDENTIFIER  019-----START REMOTE IDENTIFIER</p>	

GIMLI, MB

VE4GIM

<p>FREQUENCY – 146.25 / <u>146.85</u></p>	<p>OFFSET – MINUS ( - 600 Hz)</p>
<p>OWNER – M.R.S.</p>	<p>CONTACT – Technical Chairperson Manitoba Repeater Society (204)-944-1914</p>
<p>LOCATION – TOP OF ELEVATOR HEAD AT DEAGIO PLANT, GIMLI.</p>	
<p>PHONE PATCH – Not Available</p>	
<p style="text-align: center;"><b><u>CODES</u></b></p> <p><b>#44</b> - Link Prefix</p> <p><b>505</b> - Disconnects Repeater from links</p> <p><b>506</b> - Re-connects Repeater to links</p> <p><b>701</b> – (MACRO 401) LINK 1 to Winnipeg,      VE4WPG, - <b>ON</b></p> <p><b>710</b> – (MACRO 410) LINK 1 to Winnipeg,      VE4WPG, - <b>OFF</b></p> <p style="text-align: center;"><b><u>TELEMETRY</u></b></p> <p style="text-align: center;"><b><u>CW</u></b></p> <p>09A-----LOCATION MESSAGE</p> <p>861-----TIME - 12 HOUR FORMAT</p> <p>862-----TIME - 24 HOUR FORMAT</p> <p>863-----DATE</p> <p>864-----DAY OF WEEK</p> <p>71A-----LINK 1 TEST</p> <p>72A-----LINK 1 TEST</p> <p>04D-----REPEATER TEST</p> <p>018-----START LOCAL IDENTIFIER</p> <p>019-----START REMOTE IDENTIFIER</p>	

STARBUCK, MB

VE4MAN

<p>FREQUENCY – 146.01 / <u>146.61</u></p>	<p>OFFSET – MINUS ( - 600 Hz)</p>																																													
<p>OWNER – M.R.S.</p>	<p>CONTACT – Technical Chairperson Manitoba Repeater Society (204)-944-1914</p>																																													
<p>LOCATION – 22 MILES WSW OF WINNIPEG, 2 MILES EAST OF STARBUCK &amp; NORTH OF HIGHWAY 2</p>																																														
<p>PHONE PATCH – Not Available</p>																																														
<p style="text-align: center;"><b><u>CODES</u></b></p> <p><b>#46</b> - Link Prefix</p> <p><b>505</b> - Disconnects Repeater from links  <b>506</b> - Re-connects Repeater to links</p> <table data-bbox="267 1150 1247 1371"> <tr> <td><b>701</b> – (MACRO 401) LINK 1 to Winnipeg,</td> <td>VE4WPG, - <b>ON</b></td> </tr> <tr> <td><b>710</b> – (MACRO 410) LINK 1 to Winnipeg,</td> <td>VE4WPG, - <b>OFF</b></td> </tr> <tr> <td><b>702</b> – (MACRO 402) LINK 2 to Portage,</td> <td>VE4PTG, - <b>ON</b></td> </tr> <tr> <td><b>720</b> – (MACRO 420) LINK 2 to Portage,</td> <td>VE4PTG, - <b>OFF</b></td> </tr> <tr> <td><b>703</b> – (MACRO 403) LINK 3 to Morris,</td> <td>VE4CDN, - <b>ON</b></td> </tr> <tr> <td><b>730</b> – (MACRO 430) LINK 3 to Morris,</td> <td>VE4CDN, - <b>OFF</b></td> </tr> </table> <p style="text-align: center;"><b><u>TELEMETRY</u></b></p> <table data-bbox="267 1566 1352 1961"> <thead> <tr> <th style="text-align: left;"><u>CW</u></th> <th style="text-align: center;">-----</th> <th style="text-align: right;"><u>VIOCE</u></th> </tr> </thead> <tbody> <tr> <td>09A-----</td> <td style="text-align: center;">LOCATION MESSAGE-----</td> <td style="text-align: right;">099D</td> </tr> <tr> <td>861-----</td> <td style="text-align: center;">TIME - 12 HOUR FORMAT-----</td> <td style="text-align: right;">8661</td> </tr> <tr> <td>862-----</td> <td style="text-align: center;">TIME - 24 HOUR FORMAT-----</td> <td style="text-align: right;">8662</td> </tr> <tr> <td>863-----</td> <td style="text-align: center;">DATE-----</td> <td style="text-align: right;">-----</td> </tr> <tr> <td>864-----</td> <td style="text-align: center;">DAY OF WEEK-----</td> <td style="text-align: right;">8663</td> </tr> <tr> <td>71A-----</td> <td style="text-align: center;">LINK 1 TEST-----</td> <td style="text-align: right;">711A</td> </tr> <tr> <td>72A-----</td> <td style="text-align: center;">LINK 1 TEST-----</td> <td style="text-align: right;">722A</td> </tr> <tr> <td>04D-----</td> <td style="text-align: center;">REPEATER TEST-----</td> <td style="text-align: right;">099A</td> </tr> <tr> <td>018-----</td> <td style="text-align: center;">START LOCAL IDENTIFIER-----</td> <td style="text-align: right;">-----</td> </tr> <tr> <td>019-----</td> <td style="text-align: center;">START REMOTE IDENTIFIER-----</td> <td style="text-align: right;">-----</td> </tr> </tbody> </table>		<b>701</b> – (MACRO 401) LINK 1 to Winnipeg,	VE4WPG, - <b>ON</b>	<b>710</b> – (MACRO 410) LINK 1 to Winnipeg,	VE4WPG, - <b>OFF</b>	<b>702</b> – (MACRO 402) LINK 2 to Portage,	VE4PTG, - <b>ON</b>	<b>720</b> – (MACRO 420) LINK 2 to Portage,	VE4PTG, - <b>OFF</b>	<b>703</b> – (MACRO 403) LINK 3 to Morris,	VE4CDN, - <b>ON</b>	<b>730</b> – (MACRO 430) LINK 3 to Morris,	VE4CDN, - <b>OFF</b>	<u>CW</u>	-----	<u>VIOCE</u>	09A-----	LOCATION MESSAGE-----	099D	861-----	TIME - 12 HOUR FORMAT-----	8661	862-----	TIME - 24 HOUR FORMAT-----	8662	863-----	DATE-----	-----	864-----	DAY OF WEEK-----	8663	71A-----	LINK 1 TEST-----	711A	72A-----	LINK 1 TEST-----	722A	04D-----	REPEATER TEST-----	099A	018-----	START LOCAL IDENTIFIER-----	-----	019-----	START REMOTE IDENTIFIER-----	-----
<b>701</b> – (MACRO 401) LINK 1 to Winnipeg,	VE4WPG, - <b>ON</b>																																													
<b>710</b> – (MACRO 410) LINK 1 to Winnipeg,	VE4WPG, - <b>OFF</b>																																													
<b>702</b> – (MACRO 402) LINK 2 to Portage,	VE4PTG, - <b>ON</b>																																													
<b>720</b> – (MACRO 420) LINK 2 to Portage,	VE4PTG, - <b>OFF</b>																																													
<b>703</b> – (MACRO 403) LINK 3 to Morris,	VE4CDN, - <b>ON</b>																																													
<b>730</b> – (MACRO 430) LINK 3 to Morris,	VE4CDN, - <b>OFF</b>																																													
<u>CW</u>	-----	<u>VIOCE</u>																																												
09A-----	LOCATION MESSAGE-----	099D																																												
861-----	TIME - 12 HOUR FORMAT-----	8661																																												
862-----	TIME - 24 HOUR FORMAT-----	8662																																												
863-----	DATE-----	-----																																												
864-----	DAY OF WEEK-----	8663																																												
71A-----	LINK 1 TEST-----	711A																																												
72A-----	LINK 1 TEST-----	722A																																												
04D-----	REPEATER TEST-----	099A																																												
018-----	START LOCAL IDENTIFIER-----	-----																																												
019-----	START REMOTE IDENTIFIER-----	-----																																												

SELKIRK, MB

VE4MBR

FREQUENCY – 147.66 / <b>147.06</b> CTCSS (PL) 127.3 Hz -3A	OFFSET – POSITIVE ( + 600 Hz)																																										
OWNER – T.S.C.G	CONTACT – BILL BOWMAN, VE4UB (204)-482-3402																																										
LOCATION – SELKIRK CITY CENTER.																																											
PHONE PATCH – Not Available																																											
<p style="text-align: center;"><b><u>CODES</u></b></p> <p>TO <i>CONNECT</i> OR <i>DISCONNECT</i> THE SELKIRK, <b>VE4MBR</b> REPEATER TO THE LINKING SYSTEM USE <b><u>CODES</u> 703 – ON</b> or <b>730 - OFF</b>                  Note: there is no prefix required for these codes – as this site does not use a Palomar Controller</p> <p><b>570</b> – CTCSS (PL) Disable</p> <p style="text-align: center;"><b><u>TELEMETRY</u></b></p> <table style="width: 100%; border-collapse: collapse;"> <thead> <tr> <th style="text-align: left;"><u>CW</u></th> <th style="text-align: right;"><u>VIOCE</u></th> </tr> </thead> <tbody> <tr> <td>09A-----</td> <td style="text-align: right;">099D</td> </tr> <tr> <td colspan="2" style="text-align: center;">LOCATION MESSAGE-----</td> </tr> <tr> <td>861-----</td> <td style="text-align: right;">8661</td> </tr> <tr> <td colspan="2" style="text-align: center;">TIME - 12 HOUR FORMAT-----</td> </tr> <tr> <td>862-----</td> <td style="text-align: right;">8662</td> </tr> <tr> <td colspan="2" style="text-align: center;">TIME - 24 HOUR FORMAT-----</td> </tr> <tr> <td>863-----</td> <td style="text-align: right;">-----</td> </tr> <tr> <td colspan="2" style="text-align: center;">DATE-----</td> </tr> <tr> <td>864-----</td> <td style="text-align: right;">8663</td> </tr> <tr> <td colspan="2" style="text-align: center;">DAY OF WEEK-----</td> </tr> <tr> <td>71A-----</td> <td style="text-align: right;">711A</td> </tr> <tr> <td colspan="2" style="text-align: center;">LINK 1 TEST-----</td> </tr> <tr> <td>72A-----</td> <td style="text-align: right;">722A</td> </tr> <tr> <td colspan="2" style="text-align: center;">LINK 1 TEST-----</td> </tr> <tr> <td>04D-----</td> <td style="text-align: right;">099A</td> </tr> <tr> <td colspan="2" style="text-align: center;">REPEATER TEST-----</td> </tr> <tr> <td>018-----</td> <td style="text-align: right;">-----</td> </tr> <tr> <td colspan="2" style="text-align: center;">START LOCAL IDENTIFIER-----</td> </tr> <tr> <td>019-----</td> <td style="text-align: right;">-----</td> </tr> <tr> <td colspan="2" style="text-align: center;">START REMOTE IDENTIFIER-----</td> </tr> </tbody> </table>		<u>CW</u>	<u>VIOCE</u>	09A-----	099D	LOCATION MESSAGE-----		861-----	8661	TIME - 12 HOUR FORMAT-----		862-----	8662	TIME - 24 HOUR FORMAT-----		863-----	-----	DATE-----		864-----	8663	DAY OF WEEK-----		71A-----	711A	LINK 1 TEST-----		72A-----	722A	LINK 1 TEST-----		04D-----	099A	REPEATER TEST-----		018-----	-----	START LOCAL IDENTIFIER-----		019-----	-----	START REMOTE IDENTIFIER-----	
<u>CW</u>	<u>VIOCE</u>																																										
09A-----	099D																																										
LOCATION MESSAGE-----																																											
861-----	8661																																										
TIME - 12 HOUR FORMAT-----																																											
862-----	8662																																										
TIME - 24 HOUR FORMAT-----																																											
863-----	-----																																										
DATE-----																																											
864-----	8663																																										
DAY OF WEEK-----																																											
71A-----	711A																																										
LINK 1 TEST-----																																											
72A-----	722A																																										
LINK 1 TEST-----																																											
04D-----	099A																																										
REPEATER TEST-----																																											
018-----	-----																																										
START LOCAL IDENTIFIER-----																																											
019-----	-----																																										
START REMOTE IDENTIFIER-----																																											

MILNER RIDGE, MB

VE4MIL

<p>FREQUENCY – 144.61 / <u>145.21</u></p>	<p>OFFSET – MINUS ( - 600 Hz)</p>												
<p>OWNER – M.R.S</p>	<p>CONTACT – Technical Chairperson Manitoba Repeater Society (204)-944-1914</p>												
<p>LOCATION – 30 MILES NE OF BEAUSEJOUR, 5 MILES NORTH OF HWY 44, EAST OF HWY 214</p>													
<p>PHONE PATCH – Not Available</p>													
<p style="text-align: center;"><b><u>CODES</u></b></p> <p><b>#42</b> - Link Prefix</p> <p><b>505</b> - Disconnects Repeater from links  <b>506</b> - Re-connects Repeater to links</p> <table border="0" style="width: 100%;"> <tr> <td><b>701</b> – (MACRO 401) LINK 1 to Winnipeg,</td> <td>VE4WPG, - <b>ON</b></td> </tr> <tr> <td><b>710</b> – (MACRO 410) LINK 1 to Winnipeg,</td> <td>VE4WPG, - <b>OFF</b></td> </tr> <tr> <td><b>702</b> – (MACRO 402) LINK 2 to Falcon Lake,</td> <td>VE4FAL, - <b>ON</b></td> </tr> <tr> <td><b>720</b> – (MACRO 420) LINK 2 to Falcon Lake,</td> <td>VE4FAL, - <b>OFF</b></td> </tr> <tr> <td><b>703</b> – (MACRO 403) LINK 3 to Selkirk,</td> <td>VE4MBR, - <b>ON</b></td> </tr> <tr> <td><b>730</b> – (MACRO 430) LINK 3 to Selkirk,</td> <td>VE4MBR, - <b>OFF</b></td> </tr> </table> <p style="text-align: center;"><b><u>TELEMETRY</u></b></p> <p style="text-align: center;"><u>CW</u></p> <p>09A-----LOCATION MESSAGE  861-----TIME - 12 HOUR FORMAT  862-----TIME - 24 HOUR FORMAT  863-----DATE  864-----DAY OF WEEK  71A-----LINK 1 TEST  72A-----LINK 1 TEST  04D-----REPEATER TEST  018-----START LOCAL IDENTIFIER  019-----START REMOTE IDENTIFIER</p>		<b>701</b> – (MACRO 401) LINK 1 to Winnipeg,	VE4WPG, - <b>ON</b>	<b>710</b> – (MACRO 410) LINK 1 to Winnipeg,	VE4WPG, - <b>OFF</b>	<b>702</b> – (MACRO 402) LINK 2 to Falcon Lake,	VE4FAL, - <b>ON</b>	<b>720</b> – (MACRO 420) LINK 2 to Falcon Lake,	VE4FAL, - <b>OFF</b>	<b>703</b> – (MACRO 403) LINK 3 to Selkirk,	VE4MBR, - <b>ON</b>	<b>730</b> – (MACRO 430) LINK 3 to Selkirk,	VE4MBR, - <b>OFF</b>
<b>701</b> – (MACRO 401) LINK 1 to Winnipeg,	VE4WPG, - <b>ON</b>												
<b>710</b> – (MACRO 410) LINK 1 to Winnipeg,	VE4WPG, - <b>OFF</b>												
<b>702</b> – (MACRO 402) LINK 2 to Falcon Lake,	VE4FAL, - <b>ON</b>												
<b>720</b> – (MACRO 420) LINK 2 to Falcon Lake,	VE4FAL, - <b>OFF</b>												
<b>703</b> – (MACRO 403) LINK 3 to Selkirk,	VE4MBR, - <b>ON</b>												
<b>730</b> – (MACRO 430) LINK 3 to Selkirk,	VE4MBR, - <b>OFF</b>												

BRUXELLES, MB

VE4HS

<p>FREQUENCY – 146.28 / <b><u>146.88</u></b></p>	<p>OFFSET – MINUS ( - 600 Hz)</p>
<p>OWNER – M.R.S</p>	<p>CONTACT – Technical Chairperson Manitoba Repeater Society (204)-944-1914</p>
<p>LOCATION – Bruxelles, MB</p>	
<p>PHONE PATCH – Not Available</p>	
<p style="text-align: center;"><b><u>CODES</u></b></p> <p>#48 - Link Prefix</p> <p style="text-align: center;"><i>No Linking at this time</i></p> <p style="text-align: center;"><b><u>TELEMETRY</u></b></p> <p style="text-align: center;"><i>No telemetry at this time.</i></p>	

WINNIPEG, MB

VE4VJ

<p>FREQUENCY – 448.50 / <u>443.50</u></p>	<p>OFFSET – POSITIVE ( + 5 MHz)</p>
<p>OWNER – M.R.S.</p>	<p>CONTACT – Technical Chairperson Manitoba Repeater Society (204)-944-1914</p>
<p>LOCATION – RICHARDSON BUILDING, MAIN &amp; PORTAGE, WINNIPEG, MB</p>	
<p>PHONE PATCH – Not Available</p>	
<p style="text-align: center;"><b><u>CODES</u></b></p> <p>FOR LINKING PURPOSES, THIS REPEATER IS CONTROLLED BY THE PALOMAR CONTROLLER CONNECTED TO THE WINNIPEG, <b>VE4WPG</b> REPEATER.</p> <p>TO <b>CONNECT</b> OR <b>DISCONNECT</b> THE WINNIPEG, <b>VE4VJ</b> REPEATER TO THE LINKING SYSTEM USE <b><u>CODES</u> 701 – ON</b> or <b>710 - OFF</b> THROUGH THE <b>VE4WPG</b> CONTROLLER.</p>	

WINNIPEG, MB

VE4WPG

FREQUENCY – 147.99 / <b><u>147.39</u></b>	OFFSET – POSITIVE ( + 600 Hz)																																																	
OWNER – M.R.S.	CONTACT – Technical Chairperson Manitoba Repeater Society (204)-944-1914																																																	
LOCATION – RICHARDSON BUILDING, MAIN & PORTAGE, WINNIPEG, MB																																																		
PHONE PATCH – Not Available																																																		
<p><b><u>CODES</u></b></p> <p><b>#45</b> - Link Prefix</p> <p><b>505</b> - Disconnects Repeater from links</p> <p><b>506</b> - Re-connects Repeater to links</p> <table data-bbox="267 1123 1258 1417"> <tr> <td><b>701</b> – (MACRO 401) LINK 1 to Winnipeg,</td> <td>VE4VJ, - <b>ON</b></td> </tr> <tr> <td><b>710</b> – (MACRO 410) LINK 1 to Winnipeg,</td> <td>VE4VJ, - <b>OFF</b></td> </tr> <tr> <td><b>702</b> – (MACRO 402) LINK 2 to Starbuck,</td> <td>VE4MAN, - <b>ON</b></td> </tr> <tr> <td><b>720</b> – (MACRO 420) LINK 2 to Starbuck,</td> <td>VE4MAN, - <b>OFF</b></td> </tr> <tr> <td><b>703</b> – (MACRO 403) LINK 3 to Milner,</td> <td>VE4MIL, - <b>ON</b></td> </tr> <tr> <td><b>730</b> – (MACRO 430) LINK 3 to Milner,</td> <td>VE4MIL, - <b>OFF</b></td> </tr> <tr> <td><b>704</b> – (MACRO 404) LINK 4 to Gimli,</td> <td>VE4GIM, - <b>ON</b></td> </tr> <tr> <td><b>740</b> – (MACRO 440) LINK 4 to Gimli,</td> <td>VE4GIM, - <b>OFF</b></td> </tr> </table> <p><b><u>TELEMETRY</u></b></p> <table data-bbox="267 1533 1356 1932"> <thead> <tr> <th style="text-align: left;"><u>CW</u></th> <th style="text-align: center;">-----</th> <th style="text-align: right;"><u>VIOCE</u></th> </tr> </thead> <tbody> <tr> <td>09A-----</td> <td style="text-align: center;">LOCATION MESSAGE-----</td> <td style="text-align: right;">099D</td> </tr> <tr> <td>861-----</td> <td style="text-align: center;">TIME - 12 HOUR FORMAT-----</td> <td style="text-align: right;">8661</td> </tr> <tr> <td>862-----</td> <td style="text-align: center;">TIME - 24 HOUR FORMAT-----</td> <td style="text-align: right;">8662</td> </tr> <tr> <td>863-----</td> <td style="text-align: center;">DATE-----</td> <td style="text-align: right;">-----</td> </tr> <tr> <td>864-----</td> <td style="text-align: center;">DAY OF WEEK-----</td> <td style="text-align: right;">8663</td> </tr> <tr> <td>71A-----</td> <td style="text-align: center;">LINK 1 TEST-----</td> <td style="text-align: right;">711A</td> </tr> <tr> <td>72A-----</td> <td style="text-align: center;">LINK 1 TEST-----</td> <td style="text-align: right;">722A</td> </tr> <tr> <td>04D-----</td> <td style="text-align: center;">REPEATER TEST-----</td> <td style="text-align: right;">099A</td> </tr> <tr> <td>018-----</td> <td style="text-align: center;">START LOCAL IDENTIFIER-----</td> <td style="text-align: right;">-----</td> </tr> <tr> <td>019-----</td> <td style="text-align: center;">START REMOTE IDENTIFIER-----</td> <td style="text-align: right;">-----</td> </tr> </tbody> </table>		<b>701</b> – (MACRO 401) LINK 1 to Winnipeg,	VE4VJ, - <b>ON</b>	<b>710</b> – (MACRO 410) LINK 1 to Winnipeg,	VE4VJ, - <b>OFF</b>	<b>702</b> – (MACRO 402) LINK 2 to Starbuck,	VE4MAN, - <b>ON</b>	<b>720</b> – (MACRO 420) LINK 2 to Starbuck,	VE4MAN, - <b>OFF</b>	<b>703</b> – (MACRO 403) LINK 3 to Milner,	VE4MIL, - <b>ON</b>	<b>730</b> – (MACRO 430) LINK 3 to Milner,	VE4MIL, - <b>OFF</b>	<b>704</b> – (MACRO 404) LINK 4 to Gimli,	VE4GIM, - <b>ON</b>	<b>740</b> – (MACRO 440) LINK 4 to Gimli,	VE4GIM, - <b>OFF</b>	<u>CW</u>	-----	<u>VIOCE</u>	09A-----	LOCATION MESSAGE-----	099D	861-----	TIME - 12 HOUR FORMAT-----	8661	862-----	TIME - 24 HOUR FORMAT-----	8662	863-----	DATE-----	-----	864-----	DAY OF WEEK-----	8663	71A-----	LINK 1 TEST-----	711A	72A-----	LINK 1 TEST-----	722A	04D-----	REPEATER TEST-----	099A	018-----	START LOCAL IDENTIFIER-----	-----	019-----	START REMOTE IDENTIFIER-----	-----
<b>701</b> – (MACRO 401) LINK 1 to Winnipeg,	VE4VJ, - <b>ON</b>																																																	
<b>710</b> – (MACRO 410) LINK 1 to Winnipeg,	VE4VJ, - <b>OFF</b>																																																	
<b>702</b> – (MACRO 402) LINK 2 to Starbuck,	VE4MAN, - <b>ON</b>																																																	
<b>720</b> – (MACRO 420) LINK 2 to Starbuck,	VE4MAN, - <b>OFF</b>																																																	
<b>703</b> – (MACRO 403) LINK 3 to Milner,	VE4MIL, - <b>ON</b>																																																	
<b>730</b> – (MACRO 430) LINK 3 to Milner,	VE4MIL, - <b>OFF</b>																																																	
<b>704</b> – (MACRO 404) LINK 4 to Gimli,	VE4GIM, - <b>ON</b>																																																	
<b>740</b> – (MACRO 440) LINK 4 to Gimli,	VE4GIM, - <b>OFF</b>																																																	
<u>CW</u>	-----	<u>VIOCE</u>																																																
09A-----	LOCATION MESSAGE-----	099D																																																
861-----	TIME - 12 HOUR FORMAT-----	8661																																																
862-----	TIME - 24 HOUR FORMAT-----	8662																																																
863-----	DATE-----	-----																																																
864-----	DAY OF WEEK-----	8663																																																
71A-----	LINK 1 TEST-----	711A																																																
72A-----	LINK 1 TEST-----	722A																																																
04D-----	REPEATER TEST-----	099A																																																
018-----	START LOCAL IDENTIFIER-----	-----																																																
019-----	START REMOTE IDENTIFIER-----	-----																																																

AUSTIN, MB

VE4ARM

FREQUENCY – 146.31 / <b><u>146.91</u></b>	OFFSET – MINUS ( - 600 Hz)
OWNER – MANITOBA AMATEUR RADIO MUSEUM.	CONTACT – Bruce Johnson VE4KQ
LOCATION – MANITOBA AGRICULTURAL MUSEUM, AUSTIN, MB	
PHONE PATCH – Not Available	
<p style="text-align: center;"><b><u>CODES</u></b></p> <p style="text-align: center;"><i>No Linking at this time</i></p> <p style="text-align: center;"><b><u>TELEMETRY</u></b></p> <p><b><u>CW</u></b></p> 09A-----LOCATION MESSAGE 861-----TIME - 12 HOUR FORMAT 862-----TIME - 24 HOUR FORMAT 863-----DATE 864-----DAY OF WEEK 71A-----LINK 1 TEST 72A-----LINK 1 TEST 04D-----REPEATER TEST 018-----START LOCAL IDENTIFIER 019-----START REMOTE IDENTIFIER	

PORTAGE LA PRAIRIE, MB

VE4PTG

FREQUENCY – 147.765 / <u>147.165</u>	OFFSET – MINUS ( + 600 Hz)
OWNER – PORTAGE AMATEUR RADIO CLUB	CONTACT – Keith Beach VE4KK
LOCATION – CIVIC BUILDING-PORTAGE LA PRAIRIE, PORTAGE LA PRAIRIE, MB	
PHONE PATCH – Not Available	
<b><u>CODES</u></b>	
<i>No Linking at this time</i>	
<b><u>TELEMETRY</u></b>	
<i>No telemetry at this time.</i>	